

**NEW!**

## HYGIENIC SECURE: OUR INDUSTRIAL VACUUM BOWL CUTTERS IN NEW TOP FORM

Vakuum Cutmix VCM 360 L, VCM 550 L



**K+G WETTER**



## HYGIENIC SECURE

For maximum hygienic performance  
in industry

How can we make meat processing easier and better? This is the question that has always driven us at K+G Wetter. With „Hygienic Secure“, the new generation of vacuum bowl cutters for industry, we are setting new standards in hygiene.

## SAFE AND STRONG IN OPERATION

Faster processes, high energy efficiency, and outstanding strengths in the field of hygiene: All this and more makes „Hygienic Secure“ the new benchmark in industrial meat processing. After all, as a brand we are known worldwide for making a big difference with clever details. Let us convince you – and set the right course with us as regards safety and economy for your production.

## HYGIENIC SECURE

New strength with a sense for the tried and tested

With its two-part lid concept, „Hygienic Secure“ intelligently combines efficiency with hygiene. Special highlight: The lid strip on the knife lid is self-adjusting and can be removed for cleaning without the need for tools. Alongside this, the lid strips and the pad for the knife lid, which can be removed without tools, can also be easily kept thoroughly clean – for maximum hygiene and product safety.

## CLEVER CONSTRUCTION

This is also ensured by a further strength of „Hygienic Secure“: There is no need for a seal between the cutter bowl and the vacuum cauldron. This keeps the sensitive area hygienically clean, as cleaning is extremely simple, quick and thorough. In addition, the success of the cleaning process can also be reliably visually monitored. The same applies to cleaning of the vacuum cauldron space: There are two generous openings under the cutter bowl. This allows you to access the entire area effortlessly and check the result of the cleaning process down to the last corner.

In addition, our new industrial vacuum bowl cutters naturally have all the proven production advantages that you are accustomed to from K+G Wetter – from the robust design to the many details that offer you more safety, hygiene and efficiency. And which simply make meat processing easier.

### LABYRINTH SEALING DISCE

for maximum protection of the knife shaft bearing

### SEAL-FREE

keeps the area between the cutter bowl and the vacuum cauldron hygienically clean

hygienically secure

### INCREASED BOWL EDGE

enables clean working, improves hygiene, and prevents production losses

### TOUCHPANEL

for intuitive operation and control – optionally with connection to CutControl (recipe management) and CutVision (quality management) software

### SEPARATELY INSTALLED JOYSTICKS

for additional increased reliability

### TWO-PART LID MADE OF 100% STAINLESS STEEL

for faster loading and thus shorter process times

### INTERNAL SWITCH CABINET/ OPTIONALLY EXTERNAL

for maximum flexibility

equipped with energy-efficient AC technology

### COOKING CUTTER

the double-walled bowl ensures the highest standard of hygiene, steam consumption reduced by approx. 30%

### INCLINED, HAND-POLISHED STAINLESS STEEL SURFACES

allow cleaning water to drain off reliably

### ROBUST CAST-IRON BASE

for low-vibration, smooth running, and a long machine lifespan

### 2 GENEROUS CLEANING FLAPS

facilitate comfortable and thorough cleaning under the bowl cutter.

### ADVANTAGES OF OUR VACUUM TECHNOLOGY

- firmer and more compact sausage meats
- no air pockets in the sausage meat, therefore notably longer life of the end product
- no discolouration of the end product
- crunchy bite and intense taste of the finished sausages

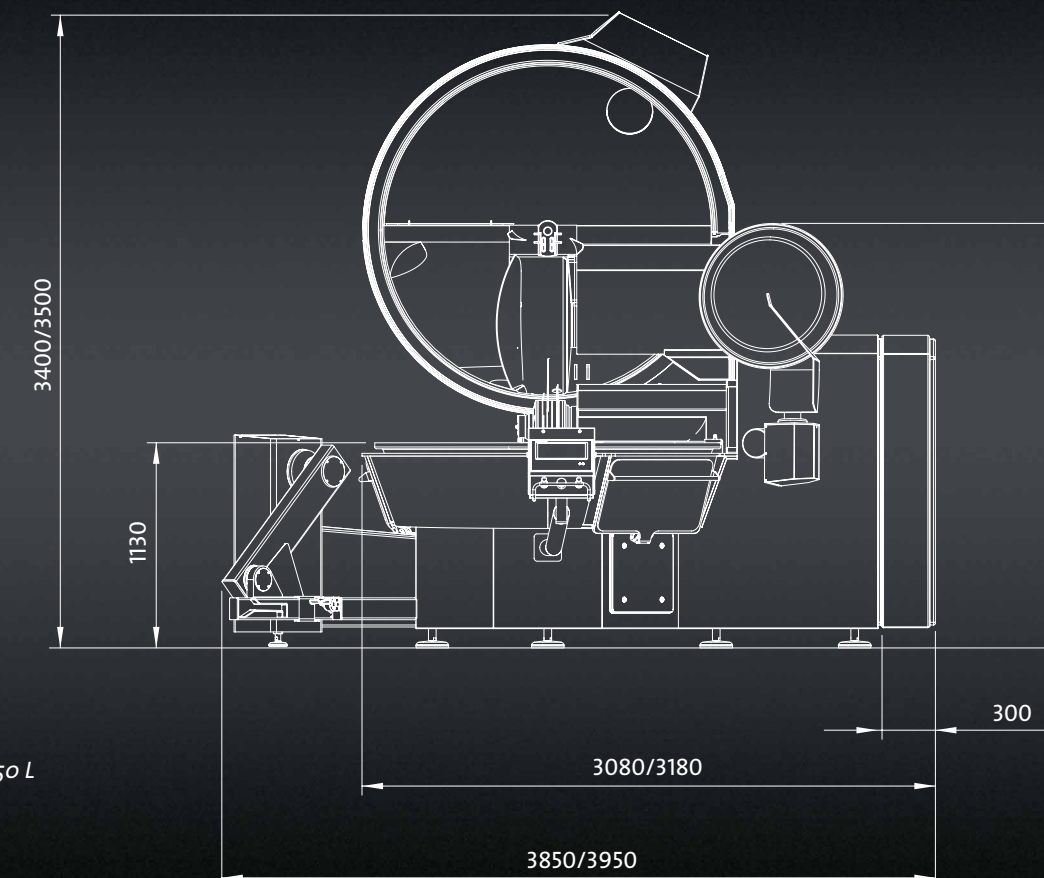

### DIMENSIONS

Vakuum Cutmix VCM 360 L / 550 L

All dimensions in mm

### TECHNICAL DATA

	VCM 360 L	VCM 550 L	
Electrical data	Type	531	551
	Operating voltage (standard)	400 V / 50 Hz	400 V / 50 Hz
	Rated connected load	170 kW	220 kW
	Rated current	370 A	470 A
Speeds	Customer-side back-up fuse	400 A gL/gG	500 A gL/gG
	Knife shaft	40–4000 rpm	40–3600 rpm
	Mixing speed (forwards and backwards)	40–500 rpm	40–500 rpm
Motor power ratings	Continuous bowl drive	4,5–16 rpm	4,5–16 rpm
	Knife shaft drive	155 kW	200 kW
	Continuous bowl drive	5,2 kW	5,2 kW
	Ejection drive	1,1 kW	1,1 kW
	Hydraulic power pack	3,6 kW	3,6 kW
Vacuum pump, integrated	Vacuum pump	5,5 kW	7,0 kW
	Pump type	Water ring	Water ring
	Water requirements (only during evacuation)	approx. 5,5 l/min	approx. 5,5 l/min
Optimum batch sizes boiled/cooked/raw sausage	290 / 280 / 160 kg	440 / 420 / 250 kg	

## HIGHLIGHTS AT A GLANCE

### 1 MAXIMUM OPERATIONAL RELIABILITY DUE TO AN UNRIVALLED HIGH STANDARD OF HYGIENE

- two-part lid made of 100% stainless steel
- vacuum lid/noise protection cover quick to open and close via hydraulics for shorter loading times
- no seal between cutter bowl and vacuum couldron, thus easy to clean
- as a result: 100% exclusion of impurities and reduced maintenance effort
- all areas of the cutter quick to clean thoroughly – even under the cutter bowl
- perfect, easily controllable cleaning result
- knife cover with self-adjusting cover strip (can be removed without tools)
- as a result: hygienically clean product area

### 2 DOUBLE-WALLED COOKING/COOLING SYSTEM\*

- completely closed system
- product does not come into contact with steam/water.
- maximum quality and hygiene

### 3 INTERNAL SWITCH CABINET OR, OPTIONALLY, EXTERNAL

- to give you more flexibility
- by default: Switch cabinet integrated in the machine body
- no external cabling required
- quick and space-efficient installation
- maximum hygiene

### 4 EXTERNAL VENTILATION\*

- standard cutter with 2 connections prepared for piping
- prevents the ingress of dust due to overpressure in the machine
- reduced wear
- dissipates 100% of warm air
- lower costs for the constant air conditioning of the work area

*\*optional*



**MADE IN  
GERMANY**

## ALL-ROUND SHARPENING SERVICE

Directly from the professionals

If the performance of your cutting tool drops after intensive use, we will restore its sharpness as soon as possible – safe transport included. More information can be found at: [kgwetter.de/schleif-service](http://kgwetter.de/schleif-service)

## A GOOD DECISION

Quality pays off

You earn your money with our machines. We are aware of this responsibility – and this can be seen in our high-quality solutions. Well thought-out down to the last detail, they ensure efficient processes and a high degree of security in your company for decades, as well as the certainty that you have made the right choice.

### DROP BY

We would be delighted to show you where and how our cutters, grinders and mixers are made for trade and industry. On a tour of our production facilities in beautiful Hessen, you will get a sense of what has always been driving us at K+G Wetter: The passion of always setting further standards with our ideas. For pure enjoyment – and your success. Worldwide.

Come and see for yourself. We are looking forward to seeing you!

**K+G WETTER**

K+G WETTER GmbH  
Goldbergstraße 21  
35216 Biedenkopf-Breidenstein

Tel. +49 (0) 64 61 / 98 40 - 0  
Fax +49 (0) 64 61 / 98 40 - 25

info@kgwetter.de  
www.kgwetter.de

