



MASCHINENPROGRAMM FÜR DIE ZERLEGUNG

MACHINES FOR BREAKING

**BESTE QUALITÄT UND SERVICE
FÜR HÖCHSTE ANSPRÜCHE
SEIT 1919.**

**BEST QUALITY AND SERVICE FOR
THE HIGHEST REQUIREMENTS.**



KATALOG EFA 400
Best.-Nr. 001 580 329



WWW.EFA-GERMANY.COM

MADE IN GERMANY



MADE FOR THE BEST

**SCHMID & WEZEL GMBH
STAMMSITZ MAULBRONN**



**MECHANISCHE
FERTIGUNG**



EFA MESSESTAND



WILLKOMMEN

Vielen Dank für Ihr Interesse an EFA.

EFA ist schon seit den 30er Jahren mit zukunftsweisender Produkttechnik an der Prozessentwicklung der Schlachtung und Zerlegung beteiligt.

Als international erfolgreicher Hersteller bieten wir unseren Kunden aus Industrie und Handwerk beständig bewährte Technik und innovative Verbesserungen.

Mit dem Ziel bestmöglicher Kundenzufriedenheit setzt das Unternehmen schon immer auf enge Zusammenarbeit mit Anwendern, deren Impulse und Kritik dankbar angenommen und in der Produktentwicklung umgesetzt werden. Ergebnis ist das stets qualitativ hochwertige EFA-Maschinen-Angebot, das den steigenden Ansprüchen an Effizienz, Ergonomie, Sicherheit und Hygiene zuvorkommt.

Neben zuverlässiger Maschinenteknik verspricht EFA einen schnellen, guten und umfangreichen Kundenservice durch eine qualifizierte Mannschaft aus gut ausgebildeten und erfahrenen Praktikern, kompetenten Handelsvertretern und Vertragshändlern auf der ganzen Welt.

DIN-ISO zertifiziert seit 1997, aufgestellt mit modernem Maschinenpark und ca. 100 aktiven Fachkräften in zeitgemäßer Unternehmensstruktur freuen wir uns auf neue Herausforderungen und blicken zuversichtlich in die Zukunft.

Wir danken all unseren Kunden und Geschäftspartnern für ihre Treue und ihr Vertrauen in so vielen Jahren und hoffen, die Zusammenarbeit noch erfolgreicher fortsetzen zu können.

WELCOME

Thank you for your interest in EFA.

EFA is instrumental in developing progressive technology and processing in the segment of slaughtery and breaking since the 30s.

As an international successfully operating producer we provide constant mature technology and innovate improvements to our customers in meat industry and butchery.

With a view to serve the customers best possible we always have been used to rely on close collaboration with the users and approve their suggestions and reviews, wich have been integrated in the product development. As a result of this best practice we have been establishing a professional high quality choice of products in every time, in advance of prospective guidelines of higher standards in efficiency, ergonomics, safety and hygiene.

In addition to reliable machine technology EFA pledges a fast and broad customer service by our qualified crew of fully-fledged practitioners, competent sales representatives and authorised dealers all over the world.

















DIN-ISO certified since 1997, equipped with modern machinery and approx. 100 skilled workers in a contemporary corporate structure we are looking confidently forward to future challenges.

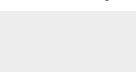

We would like to thank all our customers and business partners for their loyalty and trust for so many years and hope to continue cooperating even more successfully.



INHALTSVERZEICHNIS

CONTENT

1. ZERLEGESÄGEN, ELEKTRISCH		ELECTRIC BREAKING SAWS	EINSATZGEBIETE APPLICATIONS	S. 6 - 15
EFA SK 18 WB	Zerlegesäge	Breaking Saw		8
EFA SK 18 S	Zerlegesäge mit Servo-Synchron-motor	Breaking Saw With Servo Synchronous Motor		9
EFA SK 23 / 18	Zerlegesäge	Breaking Saw		10
EFA SK 30 / 18	Zerlegesäge	Breaking Saw		11
EFA 85 / EFA 185	Zerlegesäge	Breaking Saw		12
EFA 86 / EFA 186	Zerlegesäge	Breaking Saw		14
2. STICHSÄGEN, ELEKTRISCH		ELECTRIC RECIPROCATING SAWS		S. 16 - 19
EFA SL 24 WB	Stichsäge	Reciprocating Saw		18
EFA 63	Stichsäge	Reciprocating Saw		19
3. ZERLEGESÄGEN MIT DRUCKLUFTANTRIEB		PNEUMATIC BREAKING SAWS		S. 20 - 25
EFA SK 08 D	Kleine Einhandzerlegesäge	Small Single Hand Breaking Saw		22
EFA SK 16-8 D	Einhandzerlegesäge	Single Hand Breaking Saw		23
EFA SK 18-8 D	Brustbein- und Zerlegesäge	Brisket and Breaking Saw		24
EFA 17 / EFA 19	Zerlegesägen	Breaking Saws		25
4. HYDRAULIKZANGEN		HYDRAULIC CUTTERS		S. 26 - 30
EFA Z 080	Einhand-Hydraulikzange	Single-Hand Hydraulic Cutter		28
EFA Z 90	Hydraulische Zerlegezange	Hydraulic Cutter for Breaking		29
EFA Z 100	Hydraulische Kopf- und Beinzange	Hydraulic Head And Leg Cutter		30
5. ZERLEGEWERKZEUGE Für verschiedene Einsatzmöglichkeiten		BREAKING TOOLS For different applications		S. 32 - 43
EFA RZ 100	Rippenzieher, pneumatisch	Rib Remover, pneumatic		34
EFA 90 D, 130 D	Trimmer, pneumatisch	Trimmer, Pneumatic		36

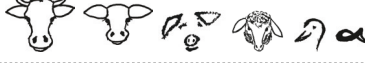
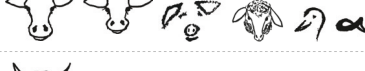
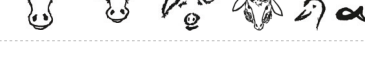
EFA 90 E, 130 E	Trimmer, elektrisch	Trimmer, Electric		37
EFA 900	Handabschwarter	Handskinner		38
EFA PK 25	Schneidmesser mit Druckluftantrieb	Pneumatic Power Knife		39
EFA 800	Schneidmesser mit Druckluftantrieb	Pneumatic Power Knife		40
EFA 802	Schneidmesser mit Druckluftantrieb	Pneumatic Power Knife		41
EFA 805	Schneidmesser mit Druckluftantrieb	Pneumatic Power Knife		42
Klingen EFA 802, EFA 805		Blades EFA 802, EFA 805		43
6. ERSATZTEILE SERVICE		SPARE-PARTS, SERVICE		S. 44 - 50
Sägeblätter für Zerlegesägen		Sawblades For Breaking Saws		46
Ersatzteilübersicht, Gewährleistungs-Hinweis		Survey of Spare Parts, Note of Liability		48
Kundendienst, Beratung, Reparatur		Sales and Customer Service, Helpdesk, Repairs		49



**ZERLEGGESÄGGEN, E
BREAKING SAWS**

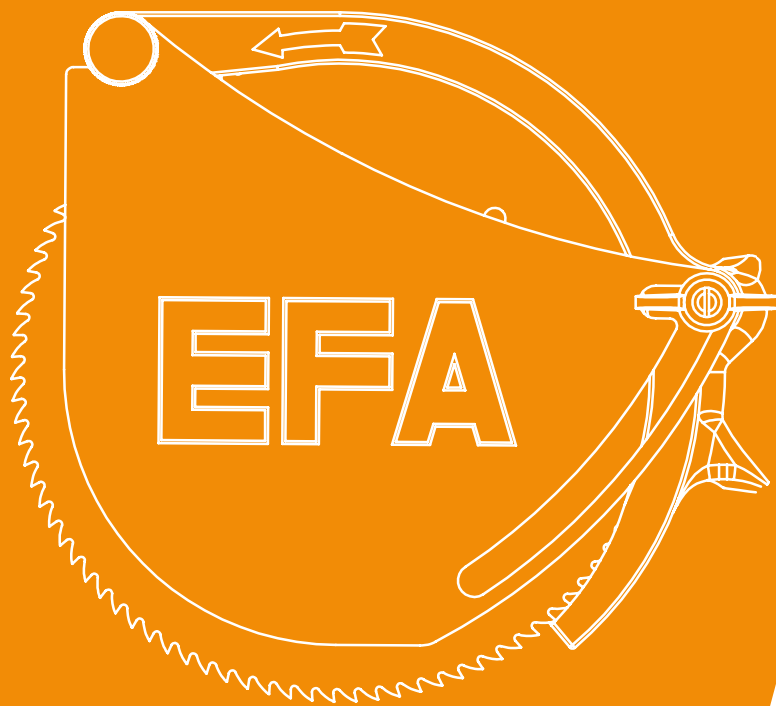

EFA SK 18 WB

ELEKTRISCHE KREISSÄGE ZUR ZERLEGUNG
ELECTRICAL CIRCULAR SAW FOR SPLITTING

ZERLEGESÄGEN, E
BREAKING SAWS



Zum Produkt
To the product



STICHSÄGEN, E
RECIPROCATING SAWS

ZERLEGESÄGEN, D
BREAKING SAWS

- » Leichte Zerlegesäge mit Universalmotor für geringe Schlachtzahlen
- » Tiefenanschlag zur Einstellung der Schnitttiefe
- » Sicher durch Motorbremse für Sägeblatt-Stopp
- » Langlebig und wartungsfreundlich

- » Lightweight circular saw, powered by an universal motor, for lower slaughtering quantities
- » Adjustable depth stop
- » Safe operation due to motor brake for sawblade-stop
- » Durable and easy to maintain

HYDRAULIKZANGEN
HYDRAULIC CUTTERS

ZERLEGEWERKZEUGE
BREAKING TOOLS

ERSATZTEILE | SERVICE
SPARE PARTS | SERVICE

Geräuschentwicklung
Ø Schalldruckpegel nach EN 11688-1
Ø Schalleistungspegel nach EN 11688-1
Noise emission
„A“ weighted sound pressure level at workstation (db) according to EN 11688-1
„A“ weighted sound power level (db)

> 85 db (A)

Hand-Arm-Vibration gem. EN 15895
Hand-arm vibration according to EN 15895

< 2,5 m/s²

LIEFERUMFANG Scope of supply	Best.-Nr. Order-No.
---------------------------------	------------------------

EFA SK 18 WB mit Standard-Sägeblatt
6 mm Verzahnung
EFA SK 18 WB with Standard sawblade,
6 mm toothing

EFA SK 18 WB, 42 V / 50 Hz, 1 Ph	110 885 330
----------------------------------	-------------

EFA SK 18 WB, 115 V / 50 Hz, 1 Ph	110 885 320
-----------------------------------	-------------

EFA SK 18 WB, 230 V / 50 Hz, 1 Ph	110 885 310
-----------------------------------	-------------

ZUBEHÖR * Accessories *	Best.-Nr. Order-No.
----------------------------	------------------------

Federzug nicht rostende Ausführung Seilauszug 2 m, Traglastbereich 4,5-7 kg Spring Balancer, stainless steel, bearing load range 4,5-7 kg, expansion length of rope 2 m	001 620 072
---	-------------

Transformator 1250 VA für 42 V Version Transformer 1250 VA for 42 V version	001 604 516
--	-------------

Getriebe-Schmierfett Transmission lubricant	
--	--

Dose, 0,75 kg 26,5 oz in a can	001 365 644
-----------------------------------	-------------

Eimer 5 kg 11 lb 0,37 oz in a bucket	001 365 645
---	-------------

EFA SK 18 WB TECHNISCHE DATEN EFA SK 18 WB Technical data

Motorleistung Motor Output	1.020 W 1,6 HP
Drehzahl Rotation speed	1.650 min ⁻¹ 1.650 rpm
Spannung Voltage	42 V / 50Hz, 115 V / 50 Hz, 230 V / 50 Hz, 1 Ph
Sägeblatt-Durchmesser Sawblade Diameter	180 mm 7"
Schnitttiefe, einstellbar Depth of cut, adjustable	15-65 mm 0,6" - 2 1/2"
Schutzart Degree of Protection	IP 24
Gewicht Weight	6,7 kg
EFA SK 18 WB Abmessung Länge EFA SK 18 WB Dimensions Length	535 mm 21"

Passende Sägeblätter für verschiedene Einsatzmöglichkeiten finden Sie in der Übersicht auf Seite 46
Please find adapted sawblades for different applications in the summary on page 46

* Nicht im Grundlieferumfang enthalten
* Not included in the basic scope of supply

EFA SK 18 S

KREISSÄGE ZUR ZERLEGUNG MIT SERVO-SYNCHRON-MOTOR
CIRCULAR SAW FOR SPLITTING WITH SERVO-SYNCHRONOUS MOTOR



Zum Produkt
To the product



- » Tiefenanschlag zur Einstellung der Schnitttiefe
- » Elektronische Bremse für Sägeblatt-Stop
- » Verschleißarm und wartungsfreundlich
- » Der Servo-Synchron-Motor:
 - » Leistungsstark,
 - » Wartungsfrei,
 - » Energie-effizient
 - » Leicht (ohne Getriebe)
 - » Hohe Standzeit
 - » Geräusch- und vibrationsarm
- » Adjustable depth stop
- » Electronic brake for sawblade-stop
- » Low-wear and easy to maintain
- » The servo-synchronous-motor:
 - » Powerful
 - » Maintenance-free
 - » Energy-efficient
 - » Lightweight version (without gear drive)
 - » Long tool life
 - » Low-noise and low vibration

EFA SK 18 S TECHNISCHE DATEN EFA SK 18 S Technical data

Motorleistung Motor Output	1.020 W 1,6 HP
Drehzahl Rotation speed	1.900 min ⁻¹ 1.900 rpm
Spannung Voltage	230 V / 50 Hz, 1 Ph
Sägeblatt-Durchmesser Sawblade Diameter	180 mm 7"
Schnitttiefe, einstellbar Depth of cut, adjustable	15-65 mm 0,6" - 2 1/2"
Schutzart Degree of Protection	IP 65

Gewicht Weight	10 kg
EFA SK 18 S Abmessung Länge (mit Sägeblatt) EFA SK 18 S Dimensions Length (with sawblade)	560 mm 22"
Geräuschentwicklung Ø Schalldruckpegel nach EN 11688-1 Ø Schalleistungspegel nach EN 11688-1 Noise emission „A“ weighted sound pressure level at workstation (db) according to EN 11688-1 „A“ weighted sound power level (db)	69 db (A)
Hand-Arm-Vibration gem. EN 15895 Hand-arm vibration according to EN 15895	< 0,7 m/s ²

LIEFERUMFANG Scope of supply	Best.-Nr. Order-No.
---------------------------------	------------------------

EFA SK 18 S 230 V / 50 Hz inkl. Spiral-Anschlußkabel, 2,8 m und Standard- Sägeblatt 6 mm Verzahnung EFA SK 18 S 230 V / 50 Hz with spiral cable, 2,8 m long and standard sawblade, 6 mm toothing	110 885 355
---	-------------

ZUBEHÖR * Accessories *	Best.-Nr Order-No.
----------------------------	-----------------------

Federzug nicht rostende Ausführung Seilanzug 2 m, Traglastbereich 9-14 kg Spring Balancer, stainless steel, bearing load range 9-14 kg, expansion length of rope 2 m	001 620 073
--	-------------

Getriebe-Schmierfett Transmission lubricant	
Dose, 0,75 kg 26,5 oz in a can	001 365 644

Eimer 5 kg 11 lb 0,37 oz in a bucket	001 365 645
---	-------------

Passende Sägeblätter für verschiedene Einsatzmöglichkeiten finden Sie in der Übersicht auf Seite 46
Please find adapted sawblades for different applications in the summary on page 46

* Nicht im Grundlieferumfang enthalten
* Not included in the basic scope of supply

ZERLEGESÄGEN, E
BREAKING SAW

STICHSÄGEN, E
RECIPROCATING SAWS

ZERLEGESÄGEN, D
BREAKING SAWS

HYDRAULIKZANGEN
HYDRAULIC CUTTERS

ZERLEGEWERKZEUGE
BREAKING TOOLS

ERSATZTEILE | SERVICE
SPARE PARTS | SERVICE

EFA SK 23 / 18

ELEKTRISCHE KREISSÄGE ZUR ZERLEGUNG
ELECTRICAL CIRCULAR SAW FOR SPLITTING

ZERLEGESÄGEN, E
BREAKING SAW

STICHSÄGEN, E
RECIPROCATING SAWS

ZERLEGESÄGEN, D
BREAKING SAWS

HYDRAULIKZANGEN
HYDRAULIC CUTTERS

ZERLEGEWERKZEUGE
BREAKING TOOLS

ERSATZTEILE | SERVICE
SPARE PARTS | SERVICE

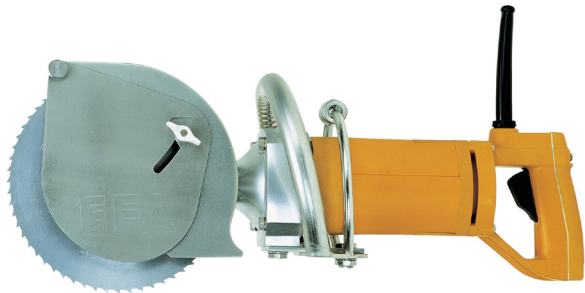

- » Leistungsstarker Universalmotor
- » Tiefenanschlag zur Einstellung der Schnitttiefe
- » Sicher durch Fliehkraftbremse für Sägeblatt-Stopp
- » Robust und wartungsfreundlich
- » Powerful universal motor
- » Adjustable depth stop
- » Safe operation due to centrifugal brake for sawblade-stop
- » Robust and easy to maintain

EFA SK 23 / 18 TECHNISCHE DATEN EFA SK 23 / 18 Technical data

Motorleistung Motor Output	1.800 W 2,4 HP
Drehzahl Rotation speed	1.350 min ⁻¹ 1.350 rpm
Spannung, erhältlich in Voltage, available in	42 V / 50-60 Hz, 230 V / 50-60Hz, 1 Ph
Sägeblatt-Durchmesser Sawblade Diameter	230 mm 9"
Schnitttiefe, einstellbar Depth of cut, adjustable	15-75 mm 0,6" - 3"
Schutzart Degree of Protection	IP 24
Gewicht Weight	9,8 kg
EFA SK 23 / 18 Abmessung Länge EFA SK 23 / 18 Dimensions Length	593 mm 23 1/4"
Geräusentwicklung Noise emission	
Ø Schalldruckpegel nach EN 11688-1 „A“ weighted sound pressure level at workstation (db) according to EN 11688-1	~ 87 db (A)

Zum Produkt
To the product



Ø Schalleistungspegel nach EN 11688-1
„A“ weighted sound power level (db) > 95 db (A)

Hand-Arm-Vibration gem. EN 15895
Hand-arm vibration according to EN 15895 < 2,5 m/s²

LIEFERUMFANG
Scope of supply

Best.-Nr.
Order-No.

EFA SK 23 / 18 mit Standard-Sägeblatt
6 mm Verzahnung
EFA SK 23 / 18 with Standard sawblade,
6 mm tothing

EFA SK 23 / 18, 42 V / 50 -60 Hz, 1 Ph 110 890 307

EFA SK 23 / 18, 230 V / 50 -60 Hz,
1 Ph 110 890 306

ZUBEHÖR *
Accessories *

Best.-Nr.
Order-No.

Federzug nicht rostende Ausführung
Seilauszug 2 m, Traglastbereich 9-14 kg
Spring Balancer, stainless steel,
bearing load range 9-14 kg, expansion
length of rope 2 m 001 620 073

Lebensmittelzugelassenes Schmierfett *¹
Accredited food safe*¹ lubrication
grease

Dose, 0,75 kg
26,5 oz in a can 001 365 623

Eimer 5 kg
11 lb 0,37 oz in a bucket 001 365 624

Getriebe-Schmierfett
Transmission lubricant

Dose, 0,75 kg
26,5 oz in a can 001 365 644

Eimer 5 kg
11 lb 0,37 oz in a bucket 001 365 645

Spannungsabhängiges Zubehör:
Voltage-dependent accessories:

Transformator 2000 VA für 42 V Version
Transformer 2000VA for 42 V version 001 604 515

Personenschutzstecker 230 V
(FI-Schutzschalter 30 mA)
Personal Safety Plug 230 V (residual-
current-circuit breaker, 30 mA) 001 603 511

Passende Sägeblätter für verschiedene Einsatzmöglichkeiten finden Sie in der Übersicht auf Seite 46
Please find adapted sawblades for different applications in the summary on page 46

* Nicht im Grundlieferumfang enthalten | * Not included in the basic scope of supply
*¹ Zulassung in Deutschland | *¹ Accreditation in Germany

EFA SK 30 / 18
ELEKTRISCHE KREISSÄGE ZUR ZERLEGUNG
ELECTRICAL CIRCULAR SAW FOR SPLITTING



Zum Produkt
To the product



ZERLEGESÄGEN, E
BREAKING SAW

STICHSÄGEN, E
RECIPROCATING SAWS

ZERLEGESÄGEN, D
BREAKING SAWS

HYDRAULIKZANGEN
HYDRAULIC CUTTERS

ZERLEGEWERKZEUGE
BREAKING TOOLS

ERSATZTEILE | SERVICE
SPARE PARTS | SERVICE

- » Leistungsstarker Universalmotor
- » Sicher durch Fliehkraftbremse für Sägeblatt-Stopp
- » Auf Schnitttiefe einstellbare Schutzhaube
- » Robust und wartungsfreundlich

- » Powerful universal motor
- » Safe operation due to centrifugal brake for sawblade-stop
- » Depth of cut-related, adjustable safety hood
- » Robust and easy to maintain

EFA SK 30 / 18
TECHNISCHE DATEN
EFA SK 30 / 18
Technical data

Motorleistung Motor Output	1.800 W 2,4 HP
Drehzahl Rotation speed	1.350 min ⁻¹ 1.350 rpm
Spannung, erhältlich in Voltage, available in	42 V / 50-60 Hz, 230 V / 50-60Hz, 1 Ph
Sägeblatt-Durchmesser Sawblade Diameter	300 mm 11 3/4"
Schnitttiefe Depth of cut	100 mm 4"
Schutzart Degree of Protection	IP 24
Gewicht Weight	11 kg
EFA SK 30 / 18 Abmessung Länge EFA SK 30 / 18 Dimensions Length	773 mm 30 1/2"
Geräuschentwicklung Noise emission	
Ø Schalldruckpegel nach EN 11688-1 „A“ weighted sound pressure level at workstation (db) according to EN 11688-1	~ 87 db (A)

Ø Schalleistungspegel nach EN 11688-1 „A“ weighted sound power level (db)	> 95 db (A)
Hand-Arm-Vibration gem. EN 15895 Hand-arm vibration according to EN 15895	< 2,5 m/s ²
LIEFERUMFANG Scope of supply	Best.-Nr. Order-No.
EFA SK 30 / 18 mit Standard-Sägeblatt 12 mm Verzahnung EFA SK 30 / 18 with Standard sawblade, 12 mm toothing	
EFA SK 30 / 18, 42 V / 50 -60 Hz, 1 Ph	110 890 407
EFA SK 30 / 18, 230 V / 50 -60 Hz, 1 Ph	110 890 406
ZUBEHÖR * Accessories *	Best.-Nr Order-No.
Federzug nicht rostende Ausführung Seilauszug 2 m, Traglastbereich 9-14 kg Spring Balancer, stainless steel, bearing load range 9-14 kg, expansion length of rope 2 m	001 620 073
Lebensmittelzugelassenes Schmierfett * ¹ Accredited food safe* ¹ lubrication grease	
Dose, 0,75 kg 26,5 oz in a can	001 365 623
Eimer 5 kg 11 lb 0,37 oz in a bucket	001 365 624
Getriebe-Schmierfett Transmission lubricant	
Dose, 0,75 kg 26,5 oz in a can	001 365 644
Eimer 5 kg 11 lb 0,37 oz in a bucket	001 365 645
Spannungsabhängiges Zubehör: Voltage-dependent accessories:	
Transformator 2000 VA für 42 V Version Transformer 2000VA for 42 V version	001 604 515
Personenschutzstecker 230 V (FI-Schutzschalter 30 mA) Personal Safety Plug 230 V (residual- current-circuit breaker, 30 mA)	001 603 511

Passende Sägeblätter für verschiedene Einsatzmöglichkeiten finden Sie in der Übersicht auf Seite 46
Please find adapted sawblades for different applications in the summary on page 46

* Nicht im Grundlieferumfang enthalten | * Not included in the basic scope of supply
*¹ Zulassung in Deutschland | *¹ Accreditation in Germany

EFA 85 / EFA 185

ELEKTRISCHE KREISSÄGE ZUR ZERLEGUNG
ELECTRICAL CIRCULAR SAW FOR SPLITTING

ZERLEGESÄGEN, E
BREAKING SAW

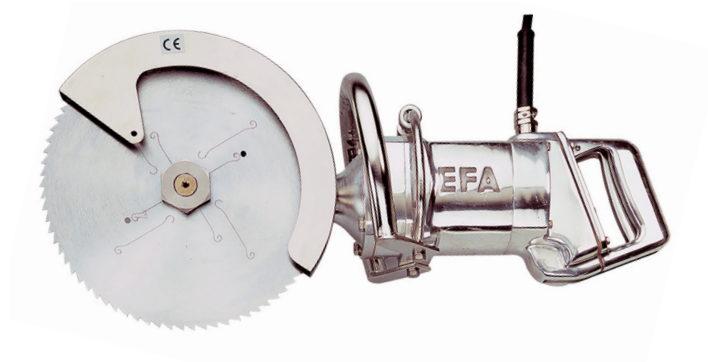

EFA 85

Zum Produkt
To the product



STICHSÄGEN, E
RECIPROCATING SAWS

ZERLEGESÄGEN, D
BREAKING SAWS

- » Leistungsstarker Drehstrommotor
- » Geschlossenes Gehäuse
- » Sicher durch Fliehkraftbremse für Sägeblatt-Stopp
- » Ergonomische Griffpositionierung
- » Glatte, reinigungsfreundliche Oberfläche

HYDRAULIKZANGEN
HYDRAULIC CUTTERS

- » Powerful three-phase motor
- » Closed housing
- » Safe operation due to centrifugal brake for sawblade-stop
- » Ergonomic installation of handles
- » Sleek surfaces, easy to sanitize

ZERLEGEWERKZEUGE
BREAKING TOOLS

ERSATZTEILE | SERVICE
SPARE PARTS | SERVICE

EFA 85 / EFA 185 TECHNISCHE DATEN EFA 85 / EFA 185 Technical data	EFA 85	EFA 185
Motorleistung Motor Output	1500 W 2 HP	
Drehzahl Rotation speed	1150 min ⁻¹ 1150 rpm	
Spannung, erhältlich in Voltage, available in	42 V / 50 Hz, 115 V / 50 Hz, 230 V / 50 Hz, 400 V / 50 Hz 3 Ph	
Sägeblatt-Durchmesser Sawblade Diameter	300 mm 11 3/4"	
Schnitttiefe Depth of cut	100 mm 4"	
Schutzart Degree of Protection	IP 65	
Gewicht, je nach Spannungsvariante Weight, depending on the voltage version	15,2-16,7 kg	
Abmessung Länge Dimensions Length	680 mm 26 3/4"	785 mm 31"
Geräuschentwicklung, Ø Schall- druckpegel nach EN 11688-1 Ø Schalleistungspegel nach EN 11688-1 Noise emission, „A“ weighted sound pressure level at worksta- tion (db) according to EN 11688-1, „A“ weighted sound power level (db)	> 85 db (A)	
Hand-Arm-Vibration gem. EN 15895 Hand-arm vibration according to EN 15895	< 2,5 m/s ²	

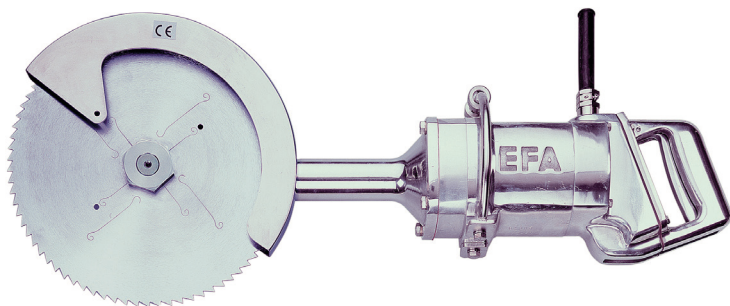

EFA 185

Zum Produkt
To the product



LIEFERUMFANG Scope of supply	EFA 85 Best.-Nr Order-No.	EFA 185 Best.-Nr Order-No.
EFA 85 / EFA 185 inkl. Standard-Sägeblatt 12 mm Verzahnung with Standard sawblade, 12 mm toothing		
42 V / 50 Hz, 3 Ph	110 886 302	110 886 312
115 V / 50 Hz, 3 Ph	110 886 305	110 886 315
230 V / 50 Hz, 3 Ph // 400 V / 50 Hz, 3 Ph	110 886 300	110 886 310
ZUBEHÖR * Accessories *	Best.-Nr Order-No.	Best.-Nr Order-No.
Federzug, nicht rostende Aus- führung, Traglastbereich 13-17 kg, Seilauszug 2 m Spring Balancer, stainless steel, bearing load range 13-17 kg, expansion length of rope 2 m		001 620 074
Lebensmittelzugelassenes Schmierfett *1 für Gleitstellen und Lager Accredited food safe*1 lubrication grease for bearings		
Dose, 0,75 kg 26,5 oz in a can		001 365 623
Eimer 5 kg 11 lb 0,37 oz in a bucket		001 365 624
Getriebe-Schmierfett Transmission lubricant		
Dose, 0,75 kg 26,5 oz in a can		001 365 644
Eimer 5 kg 11 lb 0,37 oz in a bucket		001 365 645
Transformator 5000 VA für 42 V Version Transformer 5000 VA for 42 V version		001 604 510

**Passende Sägeblätter für verschiedene Einsatzmöglichkeiten
finden Sie in der Übersicht auf Seite 46**
Please find adapted sawblades for different applications in the
summary on page 46

* Nicht im Grundlieferumfang enthalten | * Not included in the basic scope of supply
*1 Zulassung in Deutschland | *1 Accreditation in Germany

ZERLEGESÄGEN, E
BREAKING SAW

STICHSÄGEN, E
RECIPROCATING SAWS

ZERLEGESÄGEN, D
BREAKING SAWS

HYDRAULIKZANGEN
HYDRAULIC CUTTERS

ZERLEGEWERKZEUGE
BREAKING TOOLS

ERSATZTEILE | SERVICE
SPARE PARTS | SERVICE

EFA 86 / EFA 186

ELEKTRISCHE KREISSÄGE ZUR ZERLEGUNG
ELECTRICAL CIRCULAR SAW FOR SPLITTING

ZERLEGESÄGEN, E
BREAKING SAW

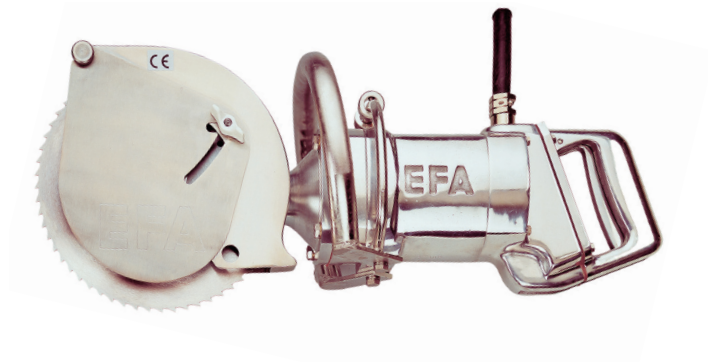

EFA 86

Zum Produkt
To the product



STICHSÄGEN, E
RECIPROCATING SAWS

ZERLEGESÄGEN, D
BREAKING SAWS

- » Leistungsstarker Drehstrommotor
- » Geschlossenes Gehäuse
- » Tiefenanschlag zur Schnittiefeinstellung
- » Sicher durch Fliehkraftbremse für Sägeblatt-Stopp
- » Ergonomische Griffpositionierung
- » Glatte, reinigungsfreundliche Oberfläche

HYDRAULIKZANGEN
HYDRAULIC CUTTERS

- » Powerful three-phase motor
- » Closed housing
- » Adjustable depth stop
- » Safe operation due to centrifugal brake for sawblade-stop
- » Ergonomic installation of handles
- » Sleek surfaces, easy to sanitize

ZERLEGEWERKZEUGE
BREAKING TOOLS

ERSATZTEILE | SERVICE
SPARE PARTS | SERVICE

EFA 86 / EFA 186 TECHNISCHE DATEN EFA 86 / EFA 186 Technical data	EFA 86	EFA 186
Motorleistung Motor Output	1500 W 2 HP	
Drehzahl Rotation speed	1150 min ⁻¹ 1150 rpm	
Spannung, erhältlich in Voltage, available in	42 V / 50 Hz, 115 V / 50 Hz, 230 V / 50 Hz, 400 V / 50 Hz 3 Ph	
Sägeblatt-Durchmesser Sawblade Diameter	230 mm 11 3/4"	
Schnitttiefe, einstellbar Depth of cut, adjustable	15-75 mm 1/2 - 3"	
Schutzart Degree of Protection	IP 65	
Gewicht, je nach Spannungsvariante Weight, depending on the voltage version	14,7-16,2 kg	
Abmessung Länge Dimensions Length	600 mm 23 1/2"	750 mm 29 1/2"
Geräuschentwicklung Ø Schall- druckpegel nach EN 11688-1 Ø Schalleistungspegel nach EN 11688-1 Noise emission „A“ weighted sound pressure level at workstation (db) according to EN 11688-1, „A“ weight- ed sound power level (db)	< 76 db (A)	
Hand-Arm-Vibration gem. EN 15895 Hand-arm vibration according to EN 15895	< 2,5 m/s ²	

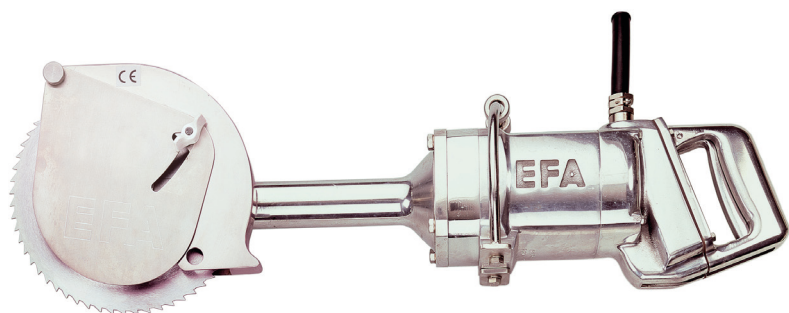

EFA 186

Zum Produkt
To the product



LIEFERUMFANG Scope of supply	EFA 86 Best.-Nr Order-No.	EFA 186 Best.-Nr Order-No.
EFA 86 / EFA 186 inkl. Standard-Sägeblatt 12 mm Verzahnung with Standard sawblade, 12 mm toothing		
42 V / 50 Hz, 3 Ph	110 886 322	110 886 332
115 V / 50 Hz, 3 Ph	110 886 325	110 886 335
230 V / 50 Hz, 3 Ph // 400 V / 50 Hz, 3 Ph	110 886 320	110 886 330
ZUBEHÖR * Accessories *	Best.-Nr Order-No.	Best.-Nr Order-No.
Federzug, nicht rostende Ausführung, Traglastbereich 13-17 kg, Seilauszug 2 m Spring Balancer, stainless steel, bearing load range 13-17 kg, expansion length of rope 2 m		001 620 074
Lebensmittelzugelassenes Schmierfett *1 für Gleitstellen und Lager Accredited food safe*1 lubrication grease for bearings		
Dose, 0,75 kg 26,5 oz in a can		001 365 623
Eimer 5 kg 11 lb 0,37 oz in a bucket		001 365 624
Getriebe-Schmierfett Transmission lubricant		
Dose, 0,75 kg 26,5 oz in a can		001 365 644
Eimer 5 kg 11 lb 0,37 oz in a bucket		001 365 645
Transformator 5000 VA für 42 V Version Transformer 5000 VA for 42 V version		001 604 510

Passende Sägeblätter für verschiedene Einsatzmöglichkeiten finden Sie in der Übersicht auf Seite 46
Please find adapted sawblades for different applications in the summary on page 46

* Nicht im Grundlieferumfang enthalten | * Not included in the basic scope of supply
*1 Zulassung in Deutschland | *1 Accreditation in Germany

ZERLEGESÄGEN, E
BREAKING SAW

STICHSÄGEN, E
RECIPROCATING SAWS

ZERLEGESÄGEN, D
BREAKING SAWS

HYDRAULIKZANGEN
HYDRAULIC CUTTERS

ZERLEGEWERKZEUGE
BREAKING TOOLS

ERSATZTEILE | SERVICE
SPARE PARTS | SERVICE

2

STICHSÄGGEN, E

RECIPROCATING SAWS

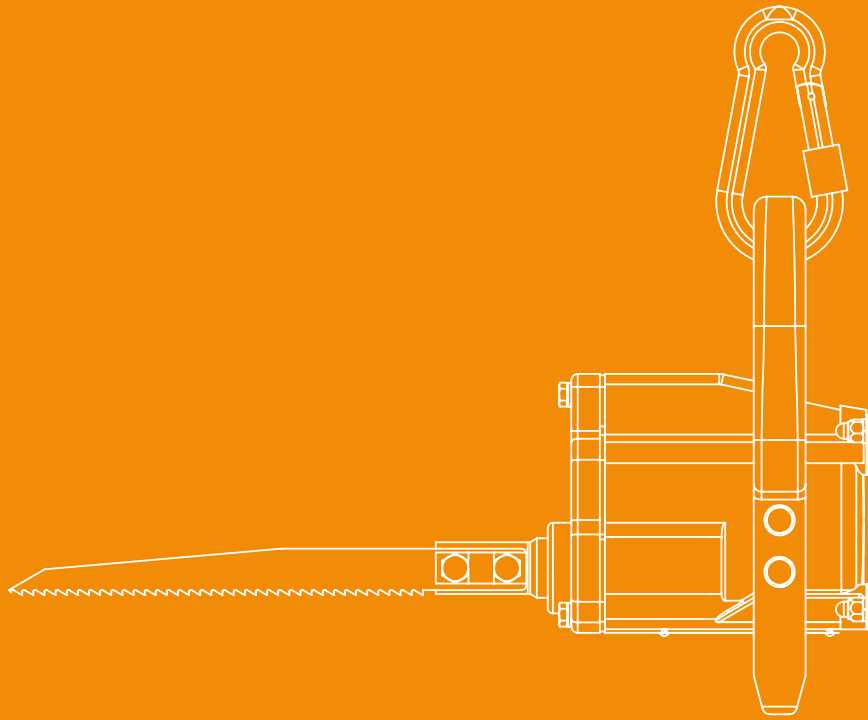

EFA SL 24 WB
ELEKTRO-STICHSÄGE
ELECTRIC RECIPROCATING SAW



Zum Produkt
To the product



- » Ideal für die Grobzerlegung; vorheriges Einschneiden nicht notwendig
 - » Schnelles Arbeiten durch kraftvolle Pendelhub-Bewegung
 - » Robuste, leistungsstarke Maschine
-
- » Most suitable for primal cut, no prior incising necessary
 - » Fast work due to powerful oscillating strokes
 - » Powerful and robust

WAHLWEISE Sägeblattlänge
OPTIONAL Sawblade Length

200 / 300 mm
7,96" / 11,8"

LIEFERUMFANG
Scope of supply

Best.-Nr.
Order-No.

EFA SL 24 WB Sticksäge mit Standard-Sägeblatt 200 mm und Anschlußkabel, 4m
EFA SL 24 WB Reciprocating Saw with standard sawblade 200 mm / 7,96" and cable set, 4 m / 4,37 yd

42 V 110 890 215

230 V 110 890 205

ZUBEHÖR *
Accessories *

Best.-Nr.
Order-No.

Sägeblatt Standard 200 mm
Sawblade, standard 200 mm / 7,96" 003 006 035

Sägeblatt lang, 300 mm
Sawblade, long, 300 mm / 11,8" 003 006 036

Federzug nicht rostende Ausführung
Seilauszug 2 m, Tragkraft 6-10 kg
Spring Balancer, stainless steel, expansion length 2,2 yd, lifting capacity 6-10 kg 001 620 032

Transformator 1250 VA für 42 V Version
Transformer 1250 VA for 42 V version 001 604 516

Schalterschütz
Relay Switch 001 604 101

* Nicht im Grundlieferumfang enthalten | * Not included in the basic scope of supply
*1 Zulassung in Deutschland | *1 Accreditation in Germany

EFA SL 24 WB
TECHNISCHE DATEN
EFA SL 24 WB
Technical data

Leistung Power	1.020 W 1,37 HP
Hubzahl Stroke rate	4.500 min ⁻¹
Hublänge Stroke Length	25 mm 1"
Spannung Voltage	42 V / 50 Hz 230 V / 50 Hz
Schutzart Degree of Protection	IP 24
Gewicht Weight	6,4 kg
EFA SL 24 WB Abmessung ohne Sägeblatt (L x B x H) EFA SL 24 WB Dimensions without sawblade (l x w x h)	500 x 150 x 230 mm 19,7" x 5,9" x 9"

ZERLEGESÄGEN, E
BREAKING SAW

STICHSÄGEN, E
RECIPROCATING SAWS

ZERLEGESÄGEN, D
BREAKING SAWS

HYDRAULIKZANGEN
HYDRAULIC CUTTERS

ZERLEGEWERKZEUGE
BREAKING TOOLS

ERSATZTEILE | SERVICE
SPARE PARTS | SERVICE

EFA 63
STICHSÄGE
RECIPROCATING SAW

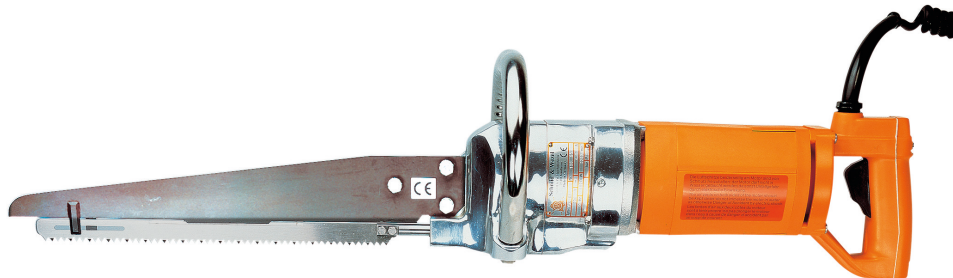

Zum Produkt
To the product



ZERLEGESÄGEN, E
BREAKING SAW

STICHSÄGEN, E
RECIPROCATING SAWS

ZERLEGESÄGEN, D
BREAKING SAWS

HYDRAULIKZANGEN
HYDRAULIC CUTTERS

ZERLEGEWERKZEUGE
BREAKING TOOLS

ERSATZTEILE | SERVICE
SPARE PARTS | SERVICE

- » Leichte, universell einsetzbare Stichsäge für Handwerksbetriebe
- » Ideal zum Abvierteln von Rindern und andere Zerlegearbeiten
- » Leistungsstarker Universalmotor
- » Ergonomischer Griff
- » Anti-Vibrationspaket
- » Lightweight, all-purpose Reciprocating Saw for craft producers
- » Perfectly right for quartering cattle, but also for other breaking operations
- » Powerful universal motor
- » Ergonomic handle
- » Anit-vibration package

EFA 63
TECHNISCHE DATEN
EFA 63
Technical data

Motorleistung Motor Output	1.020 W 1,36 HP
Hubzahl Stroke rate	2.500 min ⁻¹
Spannung erhältlich in: Voltage available in:	42 V, 115 V, 230 V / 50-60 Hz
Schutzart Degree of Protection	IP 24
Sägeblatt-Länge Sawblade Length	350 mm
Gewicht Weight	7,1 kg
EFA 63 Abmessung / Gesamtlänge EFA 63 Dimensions / total length	890 mm

Geräuschentwicklung
Ø Schalldruckpegel nach EN 11688-1
Noise emission „A“ weighted sound
pressure level at workstation (db) accor-
ding to EN 11688-1

87 db (A) max.

Hand-Arm-Vibration gem. EN 28662
Hand-arm vibration according to EN
28662

< 28 m/s²

LIEFERUMFANG Scope of supply	Best.-Nr. Order-No.
EFA 63 42 V / 50-60 Hz	110 888 121
EFA 63 115 V / 50-60 Hz	110 888 111
EFA 63 230 V / 50-60 Hz	110 888 101

ZUBEHÖR * Accessories *	Best.-Nr Order-No.
Sägeblatt, 350 mm, 55 Zähne Sawblade 350 mm, 55 teeth	003 009 201
Federzug nicht rostende Ausführung Traglastbereich 6-10 kg, Seilauszug 2 m Spring Balancer, stainless steel, bearing load range 6-10 kg, expansion length of rope 2 m	001 620 075
Transformator 1250 W für 42 V-Version Transformer 1250 W for 42 V-version	001 604 516
Lebensmittelzugelassenes Schmierfett *1 Accredited food safe*1 lubrication grease	
Dose, 0,75 kg 26,5 oz in a can	001 365 623
Eimer 5 kg 11 lb 0,37 oz in a bucket	001 365 624
Getriebe-Schmierfett Transmission lubricant	
Dose, 0,75 kg 26,5 oz in a can	001 365 644
Eimer 5 kg 11 lb 0,37 oz in a bucket	001 365 645

* Nicht im Grundlieferumfang enthalten | * Not included in the basic scope of supply
*1 Zulassung in Deutschland | *1 Accreditation in Germany

3

ZERLEGGESÄGGEN, D
BREAKING SAWS

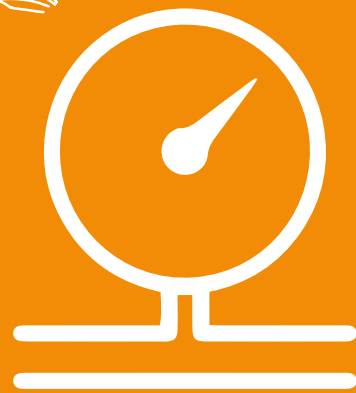
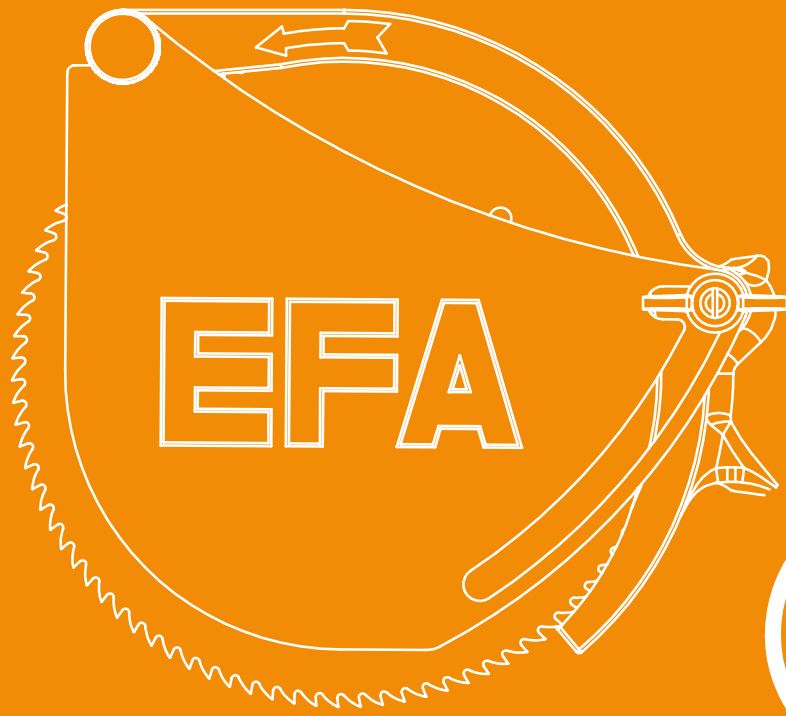

EFA SK 08 D

KLEINE EINHANDZERLEGESÄGE MIT DRUCKLUFTANTRIEB
SMALL PNEUMATIC BREAKING SAW FOR ONE-HAND OPERATION

ZERLEGESÄGEN, E
BREAKING SAWS



STICHSÄGEN, E
RECIPROCATING SAWS



Zum Produkt
To the product



ZERLEGESÄGEN, D
BREAKING SAWS

HYDRAULIKZANGEN
HYDRAULIC CUTTERS

ZERLEGEWERKZEUGE
BREAKING TOOLS

ERSATZTEILE | SERVICE
SPARE PARTS | SERVICE

- » Sehr leicht und handlich
- » Robust und wartungsfreundlich
- » Lightweight and handy
- » Robust and easy to maintain

EFA SK 08 D TECHNISCHE DATEN EFA SK 08 D Technical data

Leistung Power Output	295 W
Drehzahl Rotation speed	2.800 min ⁻¹ 2.800 rpm
Betriebsdruck Operation Pressure	6-8 bar 90-120 PSI
Luftverbrauch Air Consumption	0,6 m ³ /min
Sägeblatt-Durchmesser Sawblade Diameter	80 mm 3,15"
Schnitttiefe Depth of cut	20 mm ¾"
Gewicht Weight	1,1 kg
EFA SK 08 D WB Abmessung Länge EFA SK 08 D Dimensions Length	215 mm 8 ½"

Geräuschentwicklung Ø Schalldruckpegel nach EN 11688-1 Ø Schalleistungspegel nach EN 11688-1 Noise emission „A“ weighted sound pressure level at workstation (db) according to EN 11688-1 „A“ weighted sound power level (db)	< 85 db (A)
Hand-Arm-Vibration gem. EN 15895 Hand-arm vibration according to EN 15895	< 2,5 m/s ²

LIEFERUMFANG Scope of supply	Best.-Nr. Order-No.
EFA SK 08 D mit Schlaucheinheit 5 m und Sägeblatt EFA SK 18 WB with air hose, 5 m and sawblade	130 101 805

ZUBEHÖR * Accessories *	Best.-Nr. Order-No.
Federzug nicht rostende Ausführung Seilauszug 2 m, Traglastbereich 0,3-1,5 kg Spring Balancer, stainless steel, bearing load range 0,3-1,5 kg, expansion length of rope 2 m	001 620 068
Sägeblatt φ 80 mm Sawblade φ 80 mm	003 009 719
Wartungseinheit R ½" Air line Lubricator R ½"	001 367 045
EFA Spezialöl für Wartungseinheit, 5 l EFA Special Oil for Air Line Lubricator, 5 l	001 365 612
Lebensmittelzugelassenes Schmierfett *1 Accredited food safe*1 lubrication grease	
Dose, 0,75 kg 26,5 oz in a can	001 365 623
Eimer 5 kg 11 lb 0,37 oz in a bucket	001 365 624

* Nicht im Grundlieferumfang enthalten | * Not included in the basic scope of supply
*1 Zulassung in Deutschland | *1 Accreditation in Germany

EFA SK 16-8 D

KLEINE EINHANDZERLEGESÄGE MIT DRUCKLUFTANTRIEB
SMALL PNEUMATIC BREAKING SAW FOR ONE-HAND OPERATION



ZERLEGESÄGEN, E
BREAKING SAW

STICHSÄGEN, E
RECIPROCATING SAWS

ZERLEGESÄGEN, D
BREAKING SAWS

HYDRAULIKZANGEN
HYDRAULIC CUTTERS

ZERLEGWERKZEUGE
BREAKING TOOLS

ERSATZTEILE | SERVICE
SPARE PARTS | SERVICE

Zum Produkt
To the product



- » Kraftvoll, leicht und handlich
 - » Mit einstellbarem Tiefenanschlag
 - » Verschiedene Sägeblätter einsetzbar
 - » zweiter Handgriff leicht abnehmbar
-
- » Powerful, lightweight and handy
 - » adjustable depth stop
 - » Different sawblades applicable
 - » Second handle easily removable

EFA SK 16-8 D TECHNISCHE DATEN EFA SK 16-8 D Technical data

Leistung Power Output	790 W
Drehzahl Rotation speed	2.000 min ⁻¹ 2.000 rpm
Betriebsdruck Operation Pressure	7 bar 105 PSI
Luftverbrauch Air Consumption	0,9 m ³ /min
Sägeblatt-Durchmesser Sawblade Diameter	160 mm 6 1/4"
Schnitttiefe, einstellbar Depth of cut, adjustable	15-45 mm 0,6-1,8"
Gewicht Weight	2,7 kg
EFA SK 16-8 D Abmessung Länge EFA SK 16-8 D Dimensions Length	340 mm 13,4"

Geräuschentwicklung
Ø Schalldruckpegel nach EN 11688-1
Ø Schalleistungspegel nach EN 11688-1
Noise emission
„A“ weighted sound pressure level at
workstation (db) according to
EN 11688-1 > 85 db (A)
„A“ weighted sound power level (db)

Hand-Arm-Vibration gem. EN 15895
Hand-arm vibration according to EN
15895 < 2,5 m/s²

LIEFERUMFANG Scope of supply	Best.-Nr. Order-No.
---------------------------------	------------------------

EFA SK 16-8 D mit Schlaucheinheit 5 m und Standard-Sägeblatt, 3,5 mm Verzahnung	110 890 510
EFA SK 16-8 D with air hose, 5 m and standard-sawblade, 3,5 mm toothing	

ZUBEHÖR * Accessories *	Best.-Nr. Order-No.
----------------------------	------------------------

Federzug nicht rostende Ausführung Seilanzug 2 m, Traglastbereich 1,5-3,0 kg Spring Balancer, stainless steel, bearing load range 1,5-3,0 kg, expansion length of rope 2 m	001 620 070
---	-------------

Wartungseinheit R 1/2" Air line Lubricator R 1/2"	001 367 045
--	-------------

EFA Spezialöl für Wartungseinheit, 5 l EFA Special Oil for Air Line Lubricator, 5 l	001 365 612
--	-------------

Lebensmittelzugelassenes Schmierfett *1 Accredited food safe*1 lubrication grease	
Dose, 0,75 kg 26,5 oz in a can	001 365 623
Eimer 5 kg 11 lb 0,37 oz in a bucket	001 365 624

Passende Sägeblätter für verschiedene Einsatzmöglichkeiten finden Sie in der Übersicht auf Seite 46
Please find adapted sawblades for different applications in the summary on page 46

* Nicht im Grundlieferumfang enthalten | * Not included in the basic scope of supply
*1 Zulassung in Deutschland | *1 Accreditation in Germany

EFA SK 18-8 D

BRUSTBEIN- UND ZERLEGESÄGE MIT DRUCKLUFTANTRIEB
PNEUMATIC (BRISKET) BREAKING SAW

ZERLEGESÄGEN, E
BREAKING SAWS

STICHSÄGEN, E
RECIPROCATING SAWS

ZERLEGESÄGEN, D
BREAKING SAWS

HYDRAULIKZANGEN
HYDRAULIC CUTTERS

ZERLEGERWERKZEUGE
BREAKING TOOLS

ERSATZTEILE | SERVICE
SPARE PARTS | SERVICE



Zum Produkt
To the product



- » Kraftvoll, leicht und handlich
- » Leicht zu reinigen
- » verschiedene Sägeblätter einsetzbar

- » Powerful, lightweight and handy
- » Easy to clean
- » Different sawblades applicable

EFA SK 18-8 D TECHNISCHE DATEN EFA SK 18-8 D Technical data

Leistung Power Output	790 W
Drehzahl Rotation speed	2.000 min ⁻¹ 2.000 rpm
Betriebsdruck Operation Pressure	7 bar 105 PSI
Luftverbrauch Air Consumption	0,9 m ³ /min
Sägeblatt-Durchmesser Sawblade Diameter	180 mm 6 1/4"
Schnitttiefe Depth of cut	60 mm 2,4"
Gewicht Weight	3,1 kg
EFA SK 18-8 D Abmessung Länge EFA SK 18-8 D Dimensions Length	390 mm 15 1/4"

Geräuschentwicklung
Ø Schalldruckpegel nach EN 11688-1
Ø Schalleistungspegel nach EN 11688-1
Noise emission
„A“ weighted sound pressure level at workstation (db) according to EN 11688-1
„A“ weighted sound power level (db)

> 85 db (A)

Hand-Arm-Vibration gem. EN 15895
Hand-arm vibration according to EN 15895

< 2,5 m/s²

LIEFERUMFANG
Scope of supply

EFA SK 18-8 D mit Schlaucheinheit 5 m und Standard-Sägeblatt, 3,5 mm Verzahnung
EFA SK 18-8 D with air hose, 5 m and standard-sawblade, 3,5 mm toothing

110 885 360

ZUBEHÖR *
Accessories *

Federzug nicht rostende Ausführung
Seilauszug 2 m, Traglastbereich 2-5 kg
Spring Balancer, stainless steel, bearing load range 2-5 kg, expansion length of rope 2 m

001 620 071

Wartungseinheit R 1/2"
Air line Lubricator R 1/2"

001 367 045

EFA Spezialöl für Wartungseinheit, 5 l
EFA Special Oil for Air Line Lubricator, 5 l

001 365 612

Lebensmittelzugelassenes Schmierfett *1
Accredited food safe*1 lubrication grease

Dose, 0,75 kg
26,5 oz in a can

001 365 623

Eimer 5 kg
11 lb 0,37 oz in a bucket

001 365 624

Passende Sägeblätter für verschiedene Einsatzmöglichkeiten finden Sie in der Übersicht auf Seite 46
Please find adapted sawblades for different applications in the summary on page 46

* Nicht im Grundlieferumfang enthalten | * Not included in the basic scope of supply
*1 Zulassung in Deutschland | *1 Accreditation in Germany

EFA 17 / EFA 19

KOMPAKTE ZERLEGESÄGEN MIT DRUCKLUFTANTRIEB COMPACT PNEUMATIC BREAKING SAWS



EFA 17

Zum Produkt
To the product



EFA 19

Zum Produkt
To the product



- » Kraftvoll, leicht und handlich
- » Leicht zu reinigen, sehr wartungsfreundlich
- » Ergonomische Griffpositionierung
- » Luftein- und -austritt oben
- » Verschiedene Sägeblätter verfügbar

- » Powerful, lightweight and handy
- » Easy to clean, low maintenance
- » Ergonomic handle position
- » Air connection on the top
- » Different sawblades available

EFA 17 / EFA 19 TECHNISCHE DATEN EFA 17 / EFA 19 Technical data	EFA 17	EFA 19
Leistung Power Output		800 W
Betriebsdruck Operation Pressure		6-8 bar 90-120 PSI
Luftverbrauch Air Consumption		1,2 m ³ /min
Drehzahl Rotation speed	1800 min ⁻¹ 1800 rpm	1200 min ⁻¹ 1200 rpm
Sägeblatt-Durchmesser Sawblade Diameter	210 mm 8 1/4"	270 mm 10 1/2"
Schnitttiefe Depth of cut	15-75 mm einstellbar durch Tiefenanschlag 0,6-3" adjustable due to depth stop	100 mm 4"
Gewicht Weight	8,4 kg	9 kg



Abmessung Länge Dimensions Length	488 mm 19 1/4"	520 mm 20 1/2"
Geräuschentwicklung Ø Schalldruckpegel nach EN 11688-1 Ø Schalleistungspiegel nach EN 11688-1 Noise emission „A“ weighted sound pressure level at workstation (db) according to EN 11688-1 „A“ weighted sound power level (db)		< 85 db (A)
Hand-Arm-Vibration gem. EN 15895 Hand-arm vibration according to EN 15895		< 2,5 m/s ²

LIEFERUMFANG Scope of supply	Best.-Nr. Order-No.	Best.-Nr. Order-No.
---------------------------------	------------------------	------------------------

EFA 17 Schlaucheinheit 5 m und Standard-Sägeblatt, 6,0 mm Verzahnung EFA 17 with air hose unit 5 m and standard-sawblade, 6,0 mm tothing	110 881 700	-
---	-------------	---

EFA 19 Schlaucheinheit 5 m und Standard-Sägeblatt, 6,0 mm Verzahnung EFA 19 with air hose unit 5 m and standard-sawblade, 6,0 mm tothing	-	110 881 900
---	---	-------------

ZUBEHÖR * Accessories *	Best.-Nr. Order-No.	Best.-Nr. Order-No.
----------------------------	------------------------	------------------------

Federzug, nicht rostende Ausführung, Traglastbereich 9-14 kg, Seilauszug 2 m Spring Balancer, stainless steel, bearing load range 9-14 kg, expansion length of rope 2 m		001 620 073
--	--	-------------

Wartungseinheit R 1/2" Air line Lubricator R 1/2"		001 367 045
--	--	-------------

EFA Spezialöl für Wartungseinheit, 5 l EFA Special Oil for Air Line Lubricator, 5 l		001 365 612
--	--	-------------

Lebensmittelzugelassenes Schmierfett *1 für Gleitstellen und Lager Accredited food safe*1 lubrication grease for bearings		
Dose, 0,75 kg 26,5 oz in a can		001 365 623

Eimer 5 kg 11 lb 0,37 oz in a bucket		001 365 624
---	--	-------------

Passende Sägeblätter für verschiedene Einsatzmöglichkeiten finden Sie in der Übersicht auf Seite 46
Please find adapted sawblades for different applications in the summary on page 46

* Nicht im Grundlieferumfang enthalten | * Not included in the basic scope of supply
*1 Zulassung in Deutschland | *1 Accreditation in Germany

ZERLEGESÄGEN, E
BREAKING SAW

STICHSÄGEN, E
RECIPROCATING SAWS

ZERLEGESÄGEN, D
BREAKING SAWS

HYDRAULIKZANGEN
HYDRAULIC CUTTERS

ZERLEGEWERKZEUGE
BREAKING TOOLS

ERSATZTEILE | SERVICE
SPARE PARTS | SERVICE

4

HYDRAULIKZANGEN

HYDRAULIC CUTTERS

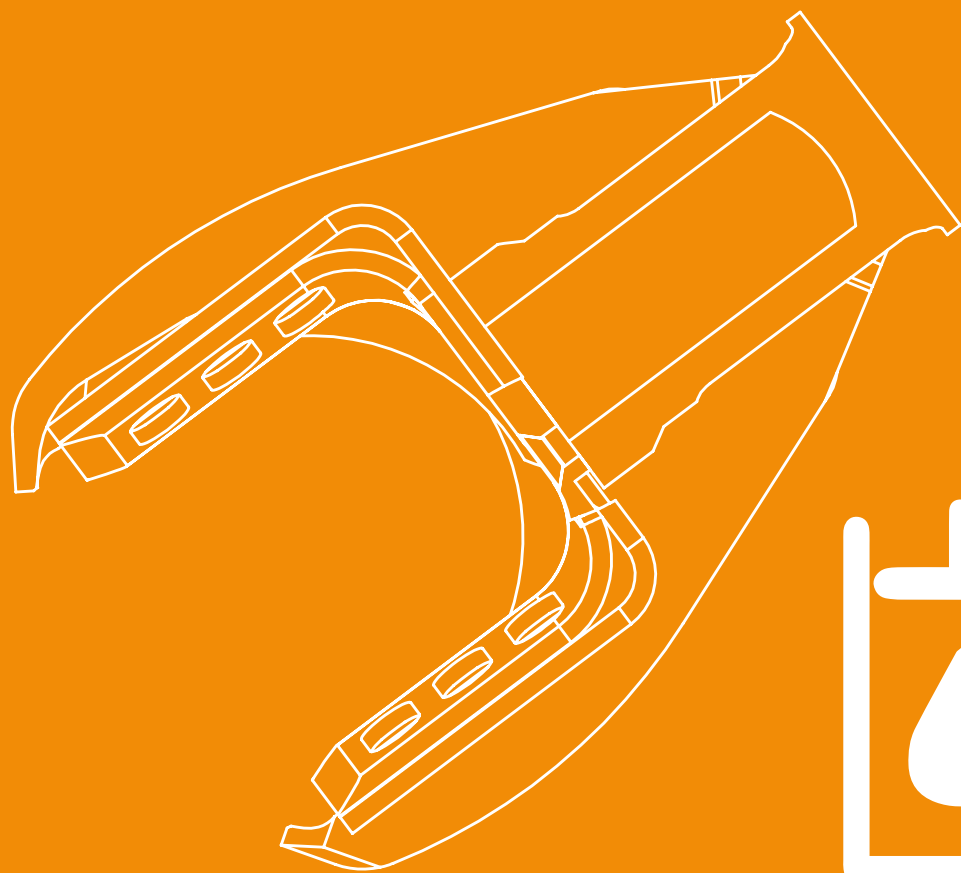

EFA Z 080
 EINHAND-HYDRAULIKZANGE
 SINGLE-HAND HYDRAULIC CUTTER



Zum Produkt
 To the product



ZERLEGESÄGEN, E
 BREAKING SAW

STICHSÄGEN, E
 RECIPROCATING SAWS

ZERLEGESÄGEN, D
 BREAKING SAWS

HYDRAULIKZANGEN
 HYDRAULIC CUTTERS

ZERLEGEWERKZEUGE
 BREAKING TOOLS

ERSATZTEILE | SERVICE
 SPARE PARTS | SERVICE

- » Zum Abtrennen von Beinen im Gelenk
- » Leicht, schnell und stark
- » Einhandbedienung
- » For Splitting legs / hocks at the joint
- » Lightweight, fast and strong
- » One hand operation

EFA Z 080 TECHNISCHE DATEN EFA Z 080 Technical data	
Zangenöffnung Opening of cutter	80 mm 3,15"
Schließkraft Clamping force	8,7 kN
Schließzeit Clamping Time	1,2 s 1,2 sec
Arbeitsdruck Working Pressure	120 bar 1740 PSI
Gewicht Weight	3,9 kg
Geräuschentwicklung Ø Schalldruckpegel nach EN 11688-1 Noise emission „A“ weighted sound pressure level at workstation (db) according to EN 11688-1	< 85 db (A)
Hand-Arm-Vibration gem. EN 15895 Hand-arm vibration according to EN 15895	< 2,5 m/s ²
LIEFERUMFANG Scope of supply	Best.-Nr. Order-No.
EFA Z 080	008 009 711

ZUBEHÖR * Accessories *	Best.-Nr Order-No.
Federzug, nicht rostende Ausführung, Traglastbereich 2-5 kg, Seilauszug 2 m Spring Balancer, stainless steel, bearing load range 2-5 kg expansion length of rope 2 m	001 620 071
Lebensmittelzugelassenes * ¹ Zangenschmierfett Accredited * ¹ food safe lubrication grease for cutter	
Dose, 0,75 kg 26,5 oz in a can	001 365 623
Eimer 5 kg 11 lb 0,37 oz in a bucket	001 365 624
Hydraulik-Schlaucheinheit, 5 m Hydraulic hose unit, 5 m	008 009 579
Hydraulik-Öl, 20 l Hydraulic Oil, 20 l	001 365 614
Elektro-Hydraulikaggregat, kpl. 230 V / 400 V, 50 Hz Electrical operated hydraulic power unit, complete 230 / 400 V, 50 Hz	001 972 461 E
Druckluft-Hydropumpe Compressed-air driven hydraulic power unit	008 006 469 D
Wartungseinheit R ½" Air line lubricator R ½"	001 367 045 D
Druckluft-Schlauch, 5 m Air hose, 5 m	001 366 812 D
Gewindenippel Threaded Nipple	001 367 102 D
¾ Wege-Handventil ¾ way hand valve	001 610 639 D
Spezial-Öl für Druckluft-Wartungseinheit, 5 l Special oil for compressed air line lubricator	001 365 612 D

* Nicht im Grundlieferumfang enthalten | * Not included in the basic scope of supply
 *¹ Zulassung in Deutschland | *¹ Accreditation in Germany

EFA Z 090
 HYDRAULISCHE ZERLEGEZANGE
 HYDRAULIC CUTTER FOR BREAKING



Zum Produkt
 To the product



ZERLEGESÄGEN, E
 BREAKING SAWS

STICHSÄGEN, E
 RECIPROCATING SAWS

ZERLEGESÄGEN, D
 BREAKING SAWS

HYDRAULIKZANGEN
 HYDRAULIC CUTTERS

ZERLEGEWERKZEUGE
 BREAKING TOOLS

ERSATZTEILE | SERVICE
 SPARE PARTS | SERVICE

- » Leicht, schnell und stark
- » 2-Hand-Sicherheitschaltung
- » Lightweight, fast and strong
- » Two hand safety actuation system

EFA Z 090 TECHNISCHE DATEN EFA Z 090 Technical data	
Zangenöffnung Opening of cutter	80 mm 3.15"
Schließkraft Clamping force	8,7 kN
Schließzeit Clamping Time	1,2 s 1,2 sec
Arbeitsdruck Working Pressure	120 bar 1740 PSI
Gewicht Weight	4,5 kg
Geräuscentwicklung Ø Schalldruckpegel nach EN 11688-1 Noise emission „A“ weighted sound pressure level at workstation (db) according to EN 11688-1	< 85 db (A)
Hand-Arm-Vibration gem. EN 15895 Hand-arm vibration according to EN 15895	< 2,5 m/s ²

LIEFERUMFANG Scope of supply	Best.-Nr. Order-No.
EFA Z 090	008 010 581
ZUBEHÖR * Accessories *	Best.-Nr Order-No.
Federzug, nicht rostende Ausführung, Traglastbereich 6-10 kg, Seilauszug 2 m Spring Balancer, stainless steel, bearing load range 6-10 kg expansion length of rope 2 m	001 620 075
Lebensmittelzugelassenes *1 Zangenschmierfett Accredited *1 food safe lubrication grease for cutter	
Dose, 0,75 kg 26,5 oz in a can	001 365 623
Eimer 5 kg 11 lb 0,37 oz in a bucket	001 365 624
Hydraulik-Schlaucheinheit, 5 m Hydraulic hose unit, 5 m	008 010 315
Hydraulik-Öl, 20 l Hydraulic Oil, 20 l	001 365 614
Elektro-Hydraulikaggregat, kpl. 230 V / 400 V, 50/60 Hz Electrical operated hydraulic power unit, complete 230 / 400 V, 50/60 Hz	008 014 173 E

* Nicht im Grundlieferumfang enthalten | * Not included in the basic scope of supply
 *1 Zulassung in Deutschland | *1 Accreditation in Germany

EFA Z 100

HYDRAULISCHE BEIN- UND KOPFZANGE HYDRAULIC CUTTER FOR LEGS AND HEADS

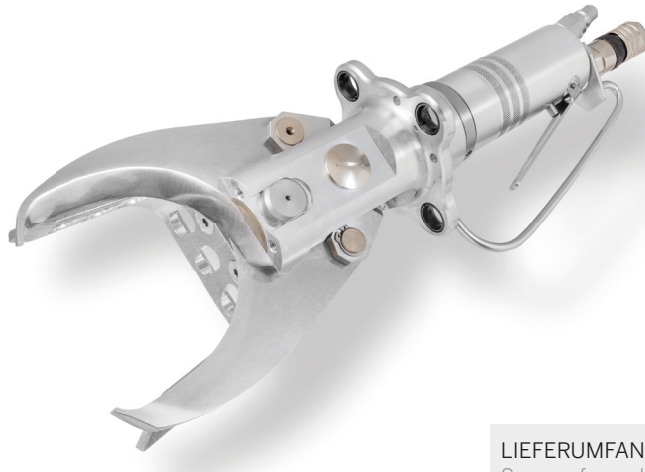

Zum Produkt
To the product



ZERLEGESÄGEN, E
BREAKING SAW

STICHSÄGEN, E
RECIPROCATING SAWS

ZERLEGESÄGEN, D
BREAKING SAWS

HYDRAULIKZANGEN
HYDRAULIC CUTTERS

ZERLEGEWERKZEUGE
BREAKING TOOLS

ERSATZTEILE | SERVICE
SPARE PARTS | SERVICE

- » Kraftvoll und schnell
- » Einhandbedienung
- » Geringes Gewicht

- » Powerful and fast
- » One hand operation
- » Lightweight

EFA Z 100 TECHNISCHE DATEN EFA Z 100 Technical data	
Zangenöffnung Opening of cutter	100 mm 4"
Schließkraft Clamping force	10 kN
Schließzeit Clamping Time	1,2 s 1,2 sec
Arbeitsdruck Working Pressure	150 bar 2175 PSI
Gewicht Weight	3,9 kg
Luftverbrauch Air Consumption	0,03 m ³ /Schnitt 0,03 m ³ /cut
EFA Z 100 Abmessung / Gesamtlänge EFA Z 100 Dimensions / total length	420 mm 16 ½"
Geräuschentwicklung Ø Schalldruckpegel nach EN 11688-1 Noise emission „A“ weighted sound pressure level at workstation (db) according to EN 11688-1	< 85 db (A)
Hand-Arm-Vibration gem. EN 15895 Hand-arm vibration according to EN 15895	< 2,5 m/s ²

LIEFERUMFANG Scope of supply	Best.-Nr. Order-No.
---------------------------------	------------------------

EFA Z 100	008 011 944
-----------	-------------

ZUBEHÖR * Accessories *	Best.-Nr. Order-No.
----------------------------	------------------------

Federzug, nicht rostende Ausführung, Traglastbereich 2-5 kg, Seilauszug 2 m Spring Balancer, stainless steel, bearing load range 2-5 kg expansion length of rope 2 m	001 620 072
---	-------------

Lebensmittelzugelassenes *1 Zangenschmierfett Accredited *1 food safe lubrication grease for cutter	
--	--

Dose, 0,75 kg 26,5 oz in a can	001 365 623
-----------------------------------	-------------

Eimer 5 kg 11 lb 0,37 oz in a bucket	001 365 624
---	-------------

Hydraulik-Schlaucheinheit, 5 m Hydraulic hose unit, 5 m	008 009 579
--	-------------

Hydraulik-Öl, 20 l Hydraulic Oil, 20 l	001 365 614
---	-------------

Elektro-Hydraulikaggregat, kpl. 400 V, 50/60 Hz Electrical operated hydraulic power unit, complete 400 V, 50/60 Hz	001 972 150 E
---	----------------------

Druckluft-Hydropumpe 6-8 bar Compressed-air driven hydraulic power unit	008 006 469 D
--	----------------------

Druckluft-Schlauch, 5 m Air hose, 5 m	001 366 812 D
--	----------------------

Wartungseinheit R ½" Air line lubricator R ½"	001 367 045 D
--	----------------------

Spezial-Öl für Druckluft-Wartungseinheit, 5 l Special oil for compressed air line lubricator	001 365 612 D
---	----------------------

* Nicht im Grundlieferumfang enthalten
* Not included in the basic scope of supply



5

ZERLEGEWERKZEUG

BREAKING TOOLS

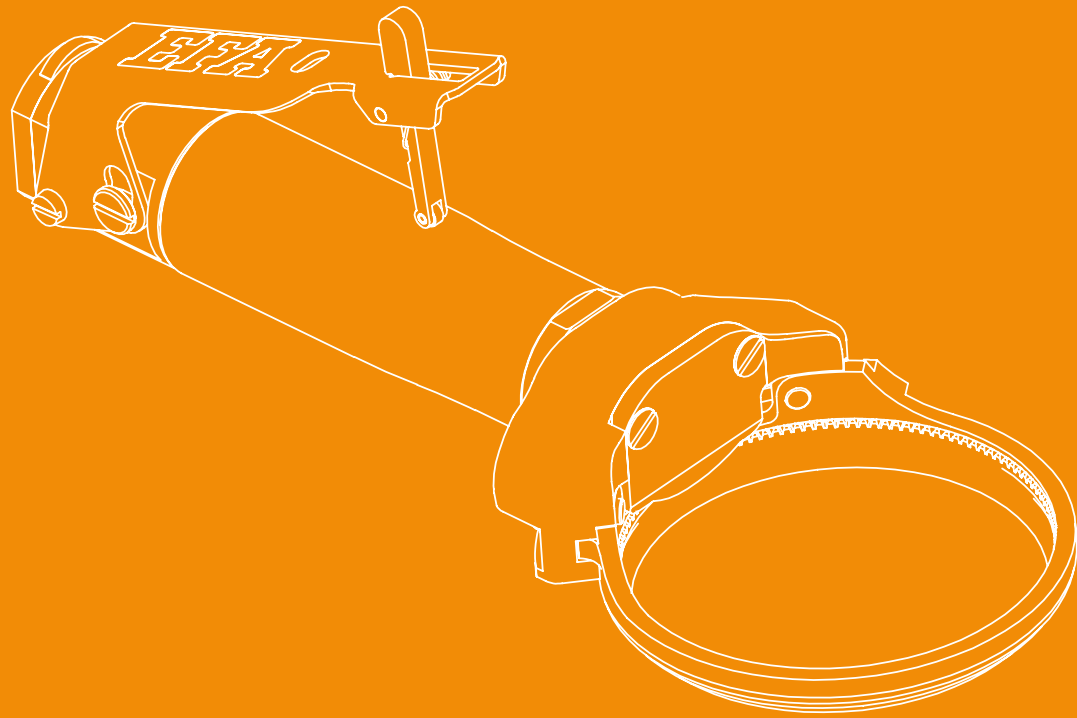

EFA RZ 100
RIPPENZIEHER PNEUMATISCH
RIB REMOVER PNEUMATIC

ZERLEGESÄGEN, E
BREAKING SAWS



STICHSÄGEN, E
RECIPROCATING SAWS

Zum Produkt
To the product



ZERLEGESÄGEN, D
BREAKING SAWS

HYDRAULIKZANGEN
HYDRAULIC CUTTERS



ZERLEGERWERKZEUGE
BREAKING TOOLS

ERSATZTEILE | SERVICE
SPARE PARTS | SERVICE

- » Patentgeschützter Rippenzieher mit konstant hoher Durchzugsleistung und hoher Standzeit
 - » Motor für Dauereinsatz
 - » Äußerst robuster Klingenhalter
 - » Verschiedene Klingengrößen einsetzbar
 - » Vibrationsarm für langes und entspanntes Arbeiten
 - » Wartungsfreundliches Gerät
-
- » Patented rib remover with constantly high engine power and long endurance
 - » Motor for continuous operation
 - » Extremely robust blade holders
 - » Different blade sizes applicable
 - » Low vibration for relaxed and long working capacity of user
 - » Easy to maintain

EFA RZ 100
TECHNISCHE DATEN
EFA RZ 100
Technical data

Leistungsaufnahme Power Consumption	300 W 0,4 HP
Hubzahl / Hub Stroke Rate / Stroke	7*500 min ⁻¹ / 8 mm
Betriebsdruck Operating Pressure	6 bar 87 PSI
Luftverbrauch Air Consumption	250 l/min 264 qt/min
Gewicht Weight	880 g 31 oz /1,94 lbs
Länge (inkl. Klingenhalter) Length (incl. Blade holder)	450 mm 17 ¾ "
Hand-Arm-Vibration gem. EN 15895 Hand-arm vibration according to EN 15895	< 2,5 m/s ²

LIEFERUMFANG
Scope of supply

EFA RZ 100 Rippenzieher, Schlaucheinheit montiert, Ø 8 mm Klingenhalter B 29 mm inklusive EFA RZ 100 Rib Remover mounted air hose unit, Ø 8 mm Blade Holder W 29 mm included	Best.-Nr. Order-No. 100 700 000
---	---------------------------------------

ZUBEHÖR *
Accessories *

Klingenhalter B 29 mm (Sauen und Eber) Blade Holder B 29 mm (Sows and Boars)	Best.-Nr. Order-No. 007 013 293
Klingenhalter B 20 mm (Schweine) Blade Holder B 20 mm (Pigs)	007 013 342
Klingen in Größen 12 – 28 mm erhältlich Blades in sizes 12 – 28 mm available	
Wartungseinheit, R ¼" Service unit, R ¼"	001 367 024
EFA Spezial- Öl, 5 l EFA Special Oil, 1,32 gal lqd	001 365 612
Schutzhandschuhe (Gr. S, M, L, XL) Safety gloves (Sizes S, M, L, XL)	

* Nicht im Grundlieferumfang enthalten
* Not included in the basic scope of supply

EFA RZ 100
 KLINGENHALTER
 BLADE HOLDERS



Klingenbreite Blade width	Best.-Nr. Order-No.	12 mm.	14 mm	16 mm	18 mm	20 mm	22 mm	28 mm	
Klingenhalter B29 (Breite 29 mm) Blade Holder B29 (width 29mm)	007 013 293				B29				Sauen und Eber Sows and Boars
Klingenhalter B20 (Breite 20 mm) Blade Holder B20 (width 20 mm)	007 013 342	B20							Schweine Pigs

ZERLEGESÄGEN, E
 BREAKING SAW

STICHSÄGEN, E
 RECIPROCATING SAWS

ZERLEGESÄGEN, D
 BREAKING SAWS

HYDRAULIKZANGEN
 HYDRAULIC CUTTERS

ZERLEGEWERKZEUGE
 BREAKING TOOLS

ERSATZTEILE | SERVICE
 SPARE PARTS | SERVICE

EFA LONGLIFE TRIMMER 90 D + 130 D

PNEUMATISCH

PNEUMATIC

ZERLEGESÄGEN,
BREAKING SAW



EFA Longlife Trimmer 130 D

Zum Produkt
To the product



STICHSÄGEN,
RECIPROCATING SAWS

ZERLEGESÄGEN,
BREAKING SAWS



EFA Longlife Trimmer 90 D

Zum Produkt
To the product



HYDRAULIKZANGEN
HYDRAULIC CUTTERS

ZERLEGEWERKZEUGE
BREAKING TOOLS

ERSATZTEILE | SERVICE
SPARE PARTS | SERVICE

- » Robust und vielseitig einsetzbar
- » Langlebige Klängen
- » Ergonomisch und vibrationsarm
- » Verschleißarm und wartungsfreundlich
- » Robust and multifunctionally applicable
- » Durable blades
- » Ergonomic and low-vibration
- » Low-wear and easy to maintain

EFA LONGLIFE TRIMMER 90 D UND 130 D TECHNISCHE DATEN EFA Longlife Trimmer 90 D und 130 D Technical data	90 D	130 D
--	------	-------

Klingendurchmesser Diameters of circular knives	90 mm 3,54"	130 mm 5,12"
Motorleistung Motor Output	215 W 0,29 HP	
Drehzahl Rotation speed	1400 min ⁻¹ 1400 rpm	900 min ⁻¹ 900 rpm
Betriebsdruck Operating Pressure	6 bar 87 PSI	

Gewicht Weight	0,81 kg	0,84 kg
-------------------	---------	---------

LIEFERUMFANG Scope of supply	Best.-Nr. Order-No.	Best.-Nr. Order-No.
---------------------------------	------------------------	------------------------

Trimmer 90 D mit Druckschlauch, 3 m Trimmer 90 D with air hose unit, 3 m / 3,28 yds	100 610 000	-
--	-------------	---

Trimmer 130 D mit Druckschlauch, 3 m Trimmer 130 D with air hose unit, 3 m / 3,28 yds	-	100 610 100
--	---	-------------

ZUBEHÖR * Accessories *	Best.-Nr. Order-No.	Best.-Nr. Order-No.
----------------------------	------------------------	------------------------

EFA SMT 100 Elektische Trimmer- klingen- Schleifmaschine Electric Trimmerblade-Sharpener	130 105 420	
---	-------------	--

beinhaltet:
includes:

Zusatz Schnitttiefeinstellung Additional Switch for depth-adjustable cut	007 014 273	007 014 311
---	-------------	-------------

Anbau Schärfeinheit Resharpener unit	007 014 274	007 014 421
---	-------------	-------------

Rundmesser Circular Knife	003 013 685	003 014 257
------------------------------	-------------	-------------

Wartungseinheit R 3/8" Air service unit R 3/8"	001 367 024	
---	-------------	--

Spezial-Öl für Wartungseinheit, 5 l Special Oil for air line lubricator, 5 l	001 365 612	
---	-------------	--

* Nicht im Grundlieferumfang enthalten
* Not included in the basic scope of supply

EFA LONGLIFE TRIMMER 90 E + 130 E
 MIT ELEKTROANTRIEB
 PELECTRICALLY POWERED



EFA Longlife Trimmer 90 E

Zum Produkt
To the product



EFA Longlife Trimmer 130 E

Zum Produkt
To the product



- » Die vielseitige Elektro-Variante
- » The multifunctional electric version



EFA SMT 100

EFA LONGLIFE TRIMMER 90 E UND 130 E TECHNISCHE DATEN EFA Longlife Trimmer 90 E und 130 E Technical data	90 E	130 E
--	------	-------

Klingendurchmesser Diameters of circular knives	90 mm 3,54"	130 mm 5,12"
--	----------------	-----------------

Motorleistung Motor Output	390 W 0,52 HP	
-------------------------------	------------------	--

Drehzahl Rotation speed	1400 min ⁻¹ 1400 rpm	900 min ⁻¹ 900 rpm
----------------------------	------------------------------------	----------------------------------

Spannung Voltage	220 – 230 V / 50 Hz	
---------------------	------------------------	--

Schutzart Degree of Protection	IP 44	
-----------------------------------	-------	--

Gewicht Weight	12 kg	12,3 kg
-------------------	-------	---------

LIEFERUMFANG Scope of supply	Best.-Nr. Order-No.	Best.-Nr. Order-No.
---------------------------------	------------------------	------------------------

Trimmer 90 E mit Elektroantrieb und biegsamer Welle Trimmer 90 E with electric drive and flexible shaft	100 640 000	-
--	-------------	---

Trimmer 130 E mit Elektroantrieb und biegsamer Welle Trimmer 130 E with electric drive and flexible shaft	-	100 640 100
--	---	-------------

ZUBEHÖR * Accessories *	Best.-Nr. Order-No.	Best.-Nr. Order-No.
----------------------------	------------------------	------------------------

EFA SMT 100 Elektrische Trimmerklingen-Schleifmaschine Electric Trimmerblade-Sharpener	130 105 420	
---	-------------	--

beinhaltet: includes:		
Zusatz Schnitttiefeinstellung Additional Switch for depth-adjustable cut	007 014 273	007 014 311

Anbau Schärfeinheit Resharpener unit	007 014 274	007 014 421
---	-------------	-------------

Rundmesser Circular Knife	003 013 685	003 014 257
------------------------------	-------------	-------------

* Nicht im Grundlieferumfang enthalten
Not included in the basic scope of supply

ZERLEGESÄGEN, E
BREAKING SAWS

STICHSÄGEN, E
RECIPROCATING SAWS

ZERLEGESÄGEN, D
BREAKING SAWS

HYDRAULIKZANGEN
HYDRAULIC CUTTERS

ZERLEGEWERKZEUGE
BREAKING TOOLS

ERSATZTEILE | SERVICE
SPARE PARTS | SERVICE

EFA 900
HANDABSCHWARTER MIT DRUCKLUFTANTRIEB
PNEUMATIC DERINDER

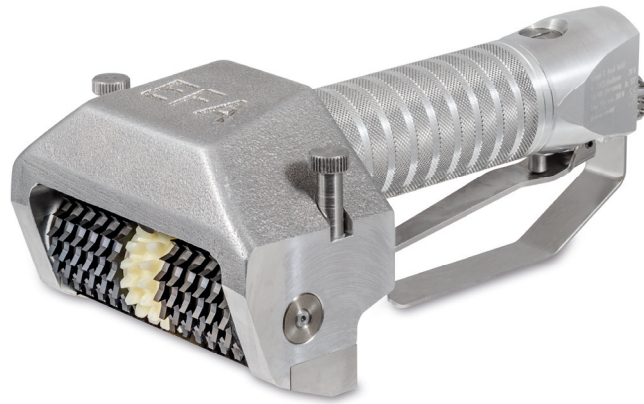

Zum Produkt
To the product



ZERLEGESÄGEN, E
BREAKING SAW

STICHSÄGEN, E
RECIPROCATING SAWS

ZERLEGESÄGEN, D
BREAKING SAWS

HYDRAULIKZANGEN
HYDRAULIC CUTTERS

ZERLEGERWERKZEUGE
BREAKING TOOLS

ERSATZTEILE | SERVICE
SPARE PARTS | SERVICE

- » Leistungsstark, leicht und handlich
- » Unterschiedliche Schnitttiefe durch Drehen der Schneide
- » Für Dauereinsatz geeignet
- » Vibrationsarm
- » Robust und wartungsfreundlich

- » Powerful, lightweight and handy
- » Turn the blade for different depth of cut
- » Applicable for continuous operation
- » Very low vibration
- » Robust and easy to maintain

EFA Z 900
TECHNISCHE DATEN
EFA Z 900
Technical data

Leistung Power Output	270 W
Drehzahl der Walze Rotation speed	420 min ⁻¹ 420 rpm
Betriebsdruck Operation Pressure	6 bar 90 PSI
Luftverbrauch Air Consumption	0,48 m ³ /min
Schnittbreite Depth of cut	95 mm 3 3/4"
Gewicht Weight	1,8 kg
Abmessung Länge Dimensions Length	221,5 mm 8 3/4"

Geräuschentwicklung
Ø Schalldruckpegel nach EN 11688-1
Ø Schalleistungspegel nach EN 11688-1
Noise emission
„A“ weighted sound pressure level at workstation (db) according to EN 11688-1
„A“ weighted sound power level (db)

< 85 db (A)

Hand-Arm-Vibration gem. EN 15895
Hand-arm vibration according to EN 15895

0,22 m/s²

LIEFERUMFANG
Scope of supply

EFA 900
mit Druckluftschlauch ϕ 7 mm und
Klingen
EFA 900 with air hose, ϕ 7 mm and
blades

100 500 000

ZUBEHÖR *
Accessories *

EFA 900 Klingen, 25 Stck.
EFA 900 Blades, 25 pcs

003 012 506

Federzug, nicht rostende Ausführung,
Traglastbereich 0,5-2 kg,
Seilauszug 2 m
Spring Balancer, stainless steel, bearing
load range 0,5-2 kg expansion length of
rope 2 m

001 620 069

Aufhängung
Suspension

007 012 860

Wartungseinheit R 1/4"
Air line Lubricator R 1/4"

001 367 024

EFA Spezialöl für Wartungseinheit, 5 l
EFA Special Oil for Air Line Lubricator,
5 l

001 365 612

* Nicht im Grundlieferumfang enthalten
* Not included in the basic scope of supply

EFA PK 25
 SCHNEIDMESSER MIT DRUCKLUFTANTRIEB
 PNEUMATIC POWER-KNIFE



Zum Produkt
 To the product



ZERLEGESÄGEN, E
 BREAKING SAWS

STICHSÄGEN, E
 RECIPROCATING SAWS

ZERLEGESÄGEN, D
 BREAKING SAWS

HYDRAULIKZANGEN
 HYDRAULIC CUTTERS

ZERLEGEWERKZEUGE
 BREAKING TOOLS

ERSATZTEILE | SERVICE
 SPARE PARTS | SERVICE



SWISS MADE

- » Sehr gut geeignet für das Abtrennen von Schwanzwirbelknochen bei Schweinen
- » Unterschiedliche Klingen verfügbar
- » Kräftiger Schnitt durch langen Hub

- » particularly suitable for detaching tail bones of hogs
- » Different blades available
- » Strong cuts due to long stroke

EFA PK 25 TECHNISCHE DATEN EFA PK 25 Technical data	
Motorleistung Motor Output	320 W 0,43 HP
Betriebsdruck Operating Pressure	7 bar 102 PSI
Hublänge / Hubfrequenz Stroke Length / Stroke frequency	25 mm / 6000/min ⁻¹
Luftverbrauch Air Consumption	350 l/min 12,36 cfm
Gewicht Weight	1,35 kg
Geräusentwicklung Ø Schalldruckpegel nach EN 11688-1 Noise emission „A“ weighted sound pressure level at workstation (db) according to EN 11688-1	79 db (A)
Hand-Arm-Vibration gem. EN ISO 28972-8 Hand-arm vibration according to EN ISO 28972-8	3,9 m/s ²
LIEFERUMFANG Scope of supply	Best.-Nr. Order-No.
EFA PK 25, ohne Klinge mit Druckluftschlaucheinheit Ø 8 mm, 3 m EFA PK 25 without blade with air hose unit Ø 0,3", 3 m	100 280 030
ZUBEHÖR * Accessories *	Best.-Nr. Order-No.
Messer, 140 mm lang Blade 5,5" long	007 009 386
Messer, 190 mm lang Blade 7,5" long	007 010 946
Wartungseinheit R 1/4" Air line lubricator R 1/4"	001 367 018
Spezial-Öl für Wartungseinheit, 5 l Special Oil for air line lubricator, 5 l	001 365 612

* Nicht im Grundlieferumfang enthalten | * Not included in the basic scope of supply

EFA 800
SCHNEIDMESSER MIT DRUCKLUFTANTRIEB
PNEUMATIC POWER KNIFE

ZERLEGESÄGEN, E
 BREAKING SAWS



Zum Produkt
 To the product



STICHSÄGEN, E
 RECIPROCATING SAWS

Die Lösung für dauerhafte Leistung bei nahezu jedem manuellen Schneidprozess.

- » Sehr leicht und handlich
- » Messer für verschiedene Anwendungen verfügbar
- » Robust und wartungsfreundlich

The solution for continuous performance in nearly every manual cutting process.

- » Lightweight and handy
- » Blades for various applications available
- » Robust and easy to maintain

ZERLEGESÄGEN, D
 BREAKING SAWS

EFA 800
TECHNISCHE DATEN
EFA 800
 Technical data

Leistung Power Output	300 W 0,4 HP
Betriebsdruck Operation Pressure	6 bar 90 PSI
Luftverbrauch Air Consumption	0,65 m ³ /min 20 cfm
Hublänge Stroke Length	8 mm
Hubfrequenz Stroke rate	11.000/min.
Gewicht Weight	0,93 kg
Abmessung Länge (ohne Messer) Dimensions Length (without knife)	208 mm 8 1/4"
Geräusentwicklung Ø Schalldruckpegel nach EN 11688-1 Ø Schalleistungspegel nach EN 11688-1 Noise emission „A“ weighted sound pressure level at workstation (db) according to EN 11688-1 „A“ weighted sound power level (db)	< 85 db (A)
Hand-Arm-Vibration gem. EN 15895 Hand-arm vibration according to EN 15895	0,22 m/s ²

HYDRAULIKZANGEN
 HYDRAULIC CUTTERS

ZERLEGEWERKZEUGE
 BREAKING TOOLS

ERSATZTEILE | SERVICE
 SPARE PARTS | SERVICE

LIEFERUMFANG
 Scope of supply

EFA 800 mit Messerpaar mit Wellenschliff, 180 mm lang und Schlaucheinheit 5 m EFA 800 with pair of serrated knives, 7" long and air hose unit, 5 m	Best.-Nr. Order-No. 100 280 000
---	---------------------------------------

ZUBEHÖR *
 Accessories *

EFA 800 Messerpaar mit Wellenschliff 155 mm EFA 800 Pair of serrated Knives 6" long	Best.-Nr. Order-No. 007 008 752
--	---------------------------------------

EFA 800 Messerpaar mit Wellenschliff 180 mm EFA 800 Pair of serrated Knives 7" long	Best.-Nr. Order-No. 007 008 753
--	---------------------------------------

Wartungseinheit R 1/4" Air line Lubricator R 1/4"	Best.-Nr. Order-No. 001 637 018
--	---------------------------------------

Wartungseinheit R 1/2" Air line Lubricator R 1/2"	Best.-Nr. Order-No. 001 367 045
--	---------------------------------------

EFA Spezialöl für Wartungseinheit, 5 l EFA Special Oil for Air Line Lubricator, 5 l	Best.-Nr. Order-No. 001 365 612
--	---------------------------------------

Lebensmittelzugelassenes *1 Zangenschmierfett Accredited *1 food safe lubrication grease for cutter	
--	--

Dose, 0,75 kg 26,5 oz in a can	Best.-Nr. Order-No. 001 365 623
-----------------------------------	---------------------------------------

Eimer 5 kg 11 lb 0,37 oz in a bucket	Best.-Nr. Order-No. 001 365 624
---	---------------------------------------

Getriebe-Schmierfett Transmission lubricant	
--	--

Dose, 0,75 kg 26,5 oz in a can	Best.-Nr. Order-No. 001 365 644
-----------------------------------	---------------------------------------

Eimer 5 kg 11 lb 0,37 oz in a bucket	Best.-Nr. Order-No. 001 365 645
---	---------------------------------------

Klingenschärfapparat ES 60 F für glatt geschliffene Messer Blade Sharpener ES 60 F for knives with smooth cut	Best.-Nr. Order-No. 001 782 501
--	---------------------------------------

Klingenschleifmaschine KSE 74 für Glattschliff Knife Grinder KSE 74 for knives with smooth cut	Best.-Nr. Order-No. 001 785 022
---	---------------------------------------

Schleifmaschine FMS 800 – 1 für Messer mit Wellenschliff Grinding Machine FMS 800 – 1 for serrated knives	Best.-Nr. Order-No. 130 105 310
--	---------------------------------------

* Nicht im Grundlieferumfang enthalten | * Not included in the basic scope of supply
 *1 Zulassung in Deutschland | *1 Accreditation in Germany

EFA 802

SCHNEIDMESSER MIT DRUCKLUFTANTRIEB PNEUMATIC POWER KNIFE



Zum Produkt
To the product



Merkmale: Siehe EFA 800 Seite 39

Characteristic: See EFA 800 page 39

EFA 802 TECHNISCHE DATEN EFA 802 Technical data	
Leistung Power Output	250 W 0,33 HP
Betriebsdruck Operation Pressure	6 bar 90 PSI
Luftverbrauch Air Consumption	0,18 m ³ /min 6,4 cfm
Hublänge Stroke Length	7 mm
Hubfrequenz Stroke rate	11.200/min.
Gewicht Weight	0,5 kg
Abmessung Länge (ohne Messer) Dimensions Length (without knife)	260 mm 10 1/4"
Geräuscentwicklung Ø Schalldruckpegel nach EN 11688-1 Ø Schalleistungspegel nach EN 11688-1 Noise emission „A“ weighted sound pressure level at workstation (db) according to EN 11688-1 „A“ weighted sound power level (db)	< 85 db (A)
Hand-Arm-Vibration gem. EN 15895 Hand-arm vibration according to EN 15895	0,22 m/s ²
LIEFERUMFANG Scope of supply	Best.-Nr. Order-No.
EFA 802 ohne Messer, mit Schlaucheinheit 5 m. Passendes Messer bitte aus Zubehör auswählen. EFA 802 without knife, with air hose unit 5 m. Please choose adequate knife from „Accessories“.	100 280 010
ZUBEHÖR * Accessories *	Best.-Nr Order-No.
EFA 802 spitz zulaufendes Messer, 140 mm „Fleischmesser“ EFA 802 tapered knife, 5 1/2" „Meat Knife“	007 009 386
EFA 802 spitz zulaufendes Messer mit Kullenschliff, 150mm EFA 802 tapered knife, scalloped edge, flat topped, 6"	007 010 738

EFA 802 spitz zulaufendes Messer, 210 mm „Gemüsemesser“ EFA 802 tapered knife, 8 1/4" „Vegetable Knife“	007 010 252
EFA 802 gerades Messer mit Kullenschliff, 190 mm „Fischmesser“ EFA 802 straight knife, scalloped edge, flat topped 7 1/2" „Fish Knife“	007 010 946
EFA 802 gerades Messer mit Kullenschliff, 300 mm „Fischmesser“ EFA 802 straight knife, scalloped edge, flat topped 11 3/4" „Fish Knife“	007 010 251
EFA 802 Anbausatz für Lachs-Carpaccio EFA 802 Attachment kit for salmon carpaccio	007 012 037
EFA 802 gerades Messer mit Wellenschliff, 220 mm „Brotmesser“ EFA 802 serrated knife, straight, flat topped 8 1/2" „Bread Knife“	007 010 254
EFA 802 gerades Messer mit Wellenschliff, 300 mm „Brotmesser“ EFA 802 serrated knife, straight, flat topped 11 3/4" „Bread Knife“	007 011 424
Wartungseinheit R 1/4" Air line Lubricator R 1/4"	001 637 018
Wartungseinheit R 1/2" Air line Lubricator R 1/2"	001 367 045
EFA Spezialöl für Wartungseinheit, 5 l EFA Special Oil for Air Line Lubricator, 5 l	001 365 612
Lebensmittelzugelassenes *1 Zangenschmierfett Accredited *1 food safe lubrication grease for cutter	
Dose, 0,75 kg 26,5 oz in a can	001 365 623
Eimer 5 kg 11 lb 0,37 oz in a bucket	001 365 624
Getriebe-Schmierfett Transmission lubricant	
Dose, 0,75 kg 26,5 oz in a can	001 365 644
Eimer 5 kg 11 lb 0,37 oz in a bucket	001 365 645
Klingenschärfapparat ES 60 F für glatt geschliffene Messer Blade Sharpener ES 60 F for knives with smooth cut	001 782 501
Klingenschleifmaschine KSE 74 für Glattschliff Knife Grinder KSE 74 for knives with smooth cut	001 785 022
Schleifmaschine FMS 800 – 1 für Messer mit Wellenschliff Grinding Machine FMS 800 – 1 for serrated knives	130 105 310

* Nicht im Grundlieferumfang enthalten | * Not included in the basic scope of supply
*1 Zulassung in Deutschland | *1 Accreditation in Germany

ZERLEGESÄGEN, E
BREAKING SAW

STICHSÄGEN, E
RECIPROCATING SAWS

ZERLEGESÄGEN, D
BREAKING SAWS

HYDRAULIKZANGEN
HYDRAULIC CUTTERS

ZERLEGEWERKZEUGE
BREAKING TOOLS

ERSATZTEILE | SERVICE
SPARE PARTS | SERVICE

EFA 805

SCHNEIDMESSER MIT DRUCKLUFTANTRIEB PNEUMATIC POWER KNIFE



Zum Produkt
To the product



Merkmale: Siehe EFA 800 Seite 39
Characteristic: See EFA 800 page 39

EFA 805 TECHNISCHE DATEN EFA 805 Technical data

Leistung Power Output	300 W 0,4 HP
Betriebsdruck Operation Pressure	6 bar 90 PSI
Luftverbrauch Air Consumption	0,25 m ³ /min 8,8 cfm
Hublänge Stroke Length	8 mm
Hubfrequenz Stroke rate	12.00/min.
Gewicht Weight	0,79 kg
Abmessung Länge (ohne Messer) Dimensions Length (without knife)	240 mm 9 1/2"
Geräuschentwicklung Ø Schalldruckpegel nach EN 11688-1 Ø Schalleistungspegel nach EN 11688-1 Noise emission „A“ weighted sound pressure level at workstation (db) according to EN 11688-1 „A“ weighted sound power level (db)	< 85 db (A)
Hand-Arm-Vibration gem. EN 15895 Hand-arm vibration according to EN 15895	0,22 m/s ²

LIEFERUMFANG Scope of supply

EFA 805 ohne Messer, mit Schlauch-einheit 2,5 m im Gerätekofter. Passendes Messer bitte aus Zubehör auswählen. EFA 805 without knife, with air hose unit 2,5 m in a case. Please choose adequate knife from „Accessories“.	100 280 050
--	-------------

ZUBEHÖR * Accessories *

EFA 805 spitz zulaufendes Messer, 140 mm „Fleischmesser“ EFA 805 tapered knife, 5 1/2" „Meat Knife“	007 009 386
EFA 805 spitz zulaufendes Messer mit Kullenschliff, 150mm EFA 805 tapered knife, scalloped edge, flat topped, 6"	007 010 738

EFA 805 spitz zulaufendes Messer, 210 mm „Gemüsemesser“
EFA 805 tapered knife, 8 1/4" „Vegetable Knife“
007 010 252

EFA 805 gerades Messer mit Kullenschliff, 190 mm „Fischmesser“
EFA 805 straight knife, scalloped edge, flat topped 7 1/2" „Fish Knife“
007 010 946

EFA 805 gerades Messer mit Kullenschliff, 300 mm „Fischmesser“
EFA 805 straight knife, scalloped edge, flat topped 11 3/4" „Fish Knife“
007 010 251

EFA 805 Anbausatz für Lachs-Carpaccio
EFA 805 Attachment kit for salmon carpaccio
007 012 037

EFA 805 gerades Messer mit Wellenschliff, 220 mm „Brotmesser“
EFA 805 serrated knife, straight, flat topped 8 1/2" „Bread Knife“
007 010 254

EFA 805 gerades Messer mit Wellenschliff, 300 mm „Brotmesser“
EFA 805 serrated knife, straight, flat topped 11 3/4" „Bread Knife“
007 011 424

Wartungseinheit R 1/4"
Air line Lubricator R 1/4"
001 637 018

Wartungseinheit R 1/2"
Air line Lubricator R 1/2"
001 367 045

EFA Spezialöl für Wartungseinheit, 5 l
EFA Special Oil for Air Line Lubricator, 5 l
001 365 612

Lebensmittelzugelassenes *1 Zangenschmierfett
Accredited *1 food safe lubrication grease for cutter

Dose, 0,75 kg
26,5 oz in a can
001 365 623

Eimer 5 kg
11 lb 0,37 oz in a bucket
001 365 624

Getriebe-Schmierfett
Transmission lubricant

Dose, 0,75 kg
26,5 oz in a can
001 365 644

Eimer 5 kg
11 lb 0,37 oz in a bucket
001 365 645

Klingenschärfapparat ES 60 F für glatt geschliffene Messer
Blade Sharpener ES 60 F for knives with smooth cut
001 782 501

Klingenschleifmaschine KSE 74 für Glattschliff
Knife Grinder KSE 74 for knives with smooth cut
001 785 022

Schleifmaschine FMS 800 – 1 für Messer mit Wellenschliff
Grinding Machine FMS 800 – 1 for serrated knives
130 105 310

* Nicht im Grundlieferumfang enthalten | * Not included in the basic scope of supply
*1 Zulassung in Deutschland | *1 Accreditation in Germany

ZERLEGESÄGEN, E
BREAKING SAWS

STICHSÄGEN, E
RECIPROCATING SAWS

ZERLEGESÄGEN, D
BREAKING SAWS

HYDRAULIKZANGEN
HYDRAULIC CUTTERS

ZERLEGEWERKZEUGE
BREAKING TOOLS

ERSATZTEILE | SERVICE
SPARE PARTS | SERVICE

KLINGEN EFA 802, EFA 805

BLADES EFA 802, EFA 805



EFA 805 gerades Messer mit Wellenschliff, 220 mm „Brotmesser“
EFA 805 serrated knife, straight, flat topped 8 1/2" „Bread Knife“

007 010 254

ZERLEGESÄGEN, E
BREAKING SAW



EFA 805 gerades Messer mit Kullenschliff, 300 mm „Fischmesser“
EFA 805 straight knife, scalloped edge, flat topped 11 3/4" „Fish Knife“

007 010 251

STICHSÄGEN, E
RECIPROCATING SAWS



EFA 805 spitz zulaufendes Messer, 210 mm „Gemüsemesser“
EFA 805 tapered knife, 8 1/4" „Vegetable Knife“

007 010 252

ZERLEGESÄGEN, D
BREAKING SAWS

HYDRAULIKZANGEN
HYDRAULIC CUTTERS



EFA 805 spitz zulaufendes Messer, 140 mm „Fleischmesser“
EFA 805 tapered knife, 5 1/2" „Meat Knife“

007 009 386

ZERLEGEWERKZEUGE
BREAKING TOOLS

ERSATZTEILE | SERVICE
SPARE PARTS | SERVICE

9

ERSATZTEILE | SERVICE
SPARE PARTS | SERVICE



SÄGEBLÄTTER FÜR ZERLEGESÄGEN

SAWBLADES FOR BREAKING SAWS

ZERLEGESÄGEN, E
BREAKING SAW



A
3,5 mm
Fein verzahnt
Fine toothting

STICHSÄGEN, E
RECIPROCATING SAWS



B
6-8 mm
Mittelfein verzahnt
Medium-fine toothting

ZERLEGESÄGEN, D
BREAKING SAWS

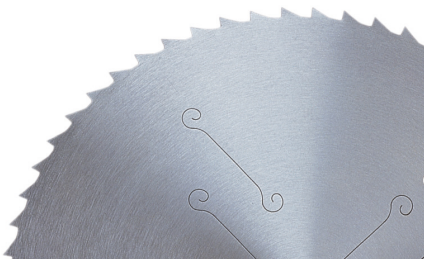

C
12-20 mm
Mittelgrob verzahnt
Medium-rough toothting

HYDRAULIKZANGEN
HYDRAULIC CUTTERS



D
40-45 mm
Grob verzahnt
Rough toothting

ZERLEGEWERKZEUGE
BREAKING TOOLS



E
Geräuscharme Verzahnung
Low noise toothting



F
Hartmetall Verzahnung (HM)
Hard metal toothting (HM)

ERSATZTEILE | SERVICE
SPARE PARTS | SERVICE

SÄGEBLÄTTER FÜR ZERLEGESÄGEN SAWBLADES FOR BREAKING SAWS

Modell Säge Saw model	Ø (mm) Ø (mm)	Zahnung (mm) Toothing (mm)	Anzahl der Zähne Nr. of teeth	Abb. Picture	Best.-Nr. Order-No.
SK 16 D	160	3,5	130	A	003 001 572
		42,0	12	D	003 001 624
		15,5 (HM)	32	F	003 008 896
SK 18 WB SK18-8 D SK 18-8 S	180	3,5	160	A	003 003 828
		6,0	94	B	003 005 185
		8,0	70	B	003 006 612
		40,5	14	D	003 003 829
		Sepzial Verzahnung Special toothing		E	001 624 418
		15,5 (HM)	36	F	003 004 917
EFA17	210	3,5	180	A	003 001 725
		6,0	110	B	003 002 028
		8,0	82	B	003 006 613
		41,0	16	D	003 001 907
		Sepzial Verzahnung Special toothing		E	001 624 420
		16,5 (HM)	40	F	003 004 918
EFA 86 EFA 186 SK 23 WB	230	6,0	120	B	003 005 312
		12,0	60	C	003 006 614
		42,5	17	D	003 009 360
		Sepzial Verzahnung Special toothing		E	001 624 422
		16,5 (HM)	44	F	003 005 313
EFA 19	270	3,5	240	A	003 001 557
		6,0	140	B	003 001 536
		12,0	70	C	003 006 615
		53,0	16	D	003 001 556
		Sepzial Verzahnung Special toothing		E	001 624 421
		16,5 (HM)	52	F	003 004 919
EFA 85 EFA 185 SK 30 WB	300	6,0	156	B	003 008 969
		12,0	78	C	003 006 429
		20,0	48	C	003 008 455
		41,0	22	D	003 009 361
		Sepzial Verzahnung Special toothing		E	001 624 423
		18,0 (HM)	52	F	003 007 187

ZERLEGESÄGEN, E
BREAKING SAWS

STICHSÄGEN, E
RECIPROCATING SAWS

ZERLEGESÄGEN, D
BREAKING SAWS

HYDRAULIKZANGEN
HYDRAULIC CUTTERS

ZERLEGEWERKZEUGE
BREAKING TOOLS

ERSATZTEILE | SERVICE
SPARE PARTS | SERVICE

ORIGINAL EFA-ERSATZTEILE

ORIGINAL EFA SPARE PARTS

Bitte bestellen Sie Ersatzteile ausschließlich beim Hersteller oder Ihrem autorisierten Händler!

Bitte beachten Sie: Garantie- und Gewährleistung gem. unseren AGB werden nur übernommen bei Einsatz von EFA Original-Ersatzteilen und Betriebsstoffen und Durchführung von Wartungs- und Instandhaltungsarbeiten durch geschultes und autorisiertes Personal gemäß den Vorgaben in der Bedienungsanleitung! Für Rückfragen stehen Ihnen Ihr EFA-Händler oder wir gerne zur Verfügung.

EFA - VERBRAUCHSMATERIAL

- » Sägeblätter für EFA-Kreis- und Hubsägen mit verschiedenen Verzahnungen für professionelle Ergebnisse in jedem Anwendungsfall
- » Sägebänder für Bandsägen
- » Enthäutermesser
- » Rundmesser für Trimmer
- » Klingen für EFA-Schneidmesser, Darmfreischneider, Rippenzieher und Abscharwer
- » Treibladung für Bolzenschussapparate
- » EFA Öle und Fette

Please order spare parts referring to the spare part lists of the instruction manuals only at the producer or your authorised dealers!

Please note that product warranty corresponding to our general terms and conditions is granted only when original EFA spare parts get installed and repairs, maintenance and service operations are made by trained and authorised personnel/dealers in accordance to the instruction manuals! For further enquiry please do not hesitate to contact your EFA dealer or us.

EFA - EXPENDABLE PARTS

- » Sawblades for EFA- Circular and reciprocating saws in various toothings for professional performance in every application
- » Sawbands
- » Dehider Blades
- » Circular Knives for Trimmers
- » Blades for EFA Powerknives, Bung Droppers, Rib Remover and Skinners
- » Premium propellant for captive bolt devices
- » EFA- Lubricating oil and grease



Schmid & Wezel ist ISO zertifiziert

ISO-certification



UNSER SERVICEANGEBOT

OUR SERVICE

REPARATURSERVICE IM HAUSE SCHMID & WEZEL

Die seit 1919 gesammelten Erfahrungen und Erkenntnisse aus Reparatur- und Wartungsarbeiten sind in unserem Haus konzentriert und ständig in praktischer Anwendung. Der Reparaturservice ist für uns ein Instrument zur Sicherung der Kundenzufriedenheit. Unsere Reparaturwerkstatt ist für die Reparatur, Instandhaltung und Wartung spezialisiert. Dieses Wissen geben wir an unsere Händler weiter.

Unsere Leistungen im Überblick:

- » 12 Monate Garantie nach hauseigener Maschinenwartung.
- » Wir verwenden ausschließlich original EFA-Ersatzteile.
- » Die Reparaturen erfolgen durch Fachleute mit langjähriger EFA-Erfahrung.
- » Die durchschnittliche Durchlaufzeit für die Reparatur einer Standardmaschine beträgt ca. zwei Wochen. Danach ist die Maschine komplett überholt.
- » Bereitstellung von Austauschmaschinen zur Überbrückung der Reparaturzeit möglich.
- » Reparatur- und Produktschulungen werden auf Wunsch für Ihr Werkstattteam, abgestimmt auf Ihren Maschinenpark bei uns durchgeführt.

Auch bei Ihnen vor Ort sind wir in Ihrer Nähe:

- » Kompetente Beratung erhalten Sie telefonisch oder elektronisch durch die technische Kundenbetreuung in unserem Haus.
- » Durch unsere Außendienstmitarbeiter erhalten Sie kompetente Beratung bei Ihnen vor Ort, Produktvorführungen und Anwenderschulungen.
- » Auf Wunsch führen unsere Fachleute auch Reparatur- und Produktschulungen in Ihrem Haus durch.
- » Testgeräte bei Neuinvestition: Zur Entscheidung stellen wir Ihnen eine, für Ihren Anwendungsfall geeignete Maschine testweise zur Verfügung.
- » Gebrauchtmachines-Angebot: die Maschinen sind generalüberholt (nur erhältlich, wenn lagerhaltig).

Ihre direkte Verbindung zu uns:

Vertrieb Inland:	+49 (0) 7343 . 102 12
Vertrieb Ausland:	+49 (0) 7343 . 102 81
Reparatur:	+49 (0) 7343 . 102 82
Fax:	+49 (0) 7343 . 102 78
E-Mail:	verkauf@efa-germany.de
Technische Kundenbetreuung /-beratung:	+49 (0) 7343 . 102 79

MAINTENANCE, REPAIRS AND SERVICE AT SCHMID & WEZELS'

Experience and knowledge gained since 1919 of EFA repairs and maintenance work are applied every day in our company. It is our understanding that our offer of service and support is supposed to be instrumental in accomplishing customer satisfaction. Our service station and staff is specialised in maintenance, repairs and service of EFA- machines. We share our knowledge with our authorised dealers.

Our service list:

- » Warranty for 12 months after in-house machine maintenance.
- » Installation of original EFA-spare parts only.
- » Repairs are made by skilled professionals with longtime experience.
- » Average time for maintenance work is approx. 2 weeks in the company; the machine will be returned completely checked and overhauled.
- » Substitution of machines during repair times possible.
- » Customized practical training courses for users and maintenance staff are hold on demand.

We are near-by:

- » We provide competent consulting service by phone or e-mail, respectively our authorised dealer near-by.
- » Due to our worldwide net of authorised dealers you will get qualified advice, support and service on-site, product demonstrations and trainings on demand.
- » Customized practical training courses are hold by qualified dealer's staff members on demand, even on-site.
- » Machines for free trial: for your purchase decision, we place an applicable machine for testing to your disposal.
- » Supply of second-hand machines: all machines are rebuilt (only available when in stock).

Your direct line to us:

Sales international:	+49 (0) 7343 . 102 81
Facsimile:	+49 (0) 7343 . 102 78
Technical service/service:	+49 (0) 7343 . 102 79
E-Mail:	verkauf@efa-germany.de

Your nearest EFA-dealer in charge:

**Schmid & Wezel GmbH
Maschinenfabrik**

Maybachstr. 2 | 75433 Maulbronn | Germany

Tel. +49 7043 . 102 0
Fax +49 7043 . 102 78

verkauf@efa-germany.de
www.efa-germany.com



**Fleischereimaschinen
Meat Processing Machines**

MADE IN GERMANY



MADE FOR THE BEST



SWISS MADE



**Schmid & Wezel GmbH
Maschinenfabrik**

Maybachstr. 2 | 75433 Maulbronn | Germany

Tel. +49 7043 . 102 0
Fax +49 7043 . 102 78

biax-verkauf@biax.de
www.biax.de



**Druckluftwerkzeuge
Pneumatic Tools**

**CH
BIAX Maschinen GmbH**

Industrieplatz | CH-8212 Neuhausen/Rheinfall

Tel. +41 52 . 674 79 79
Fax +41 52 . 674 65 64

info@biax.ch
www.biax-schweiz.ch



**Schleifspindeln und Roboterwerkzeuge
Grinding spindles and robot toolings**

**I
BIAX Italia S.r.l.**

Zona Industriale | Via del Garda 46/N
I-38068 Rovereto (TN)

Tel. +39 464 . 433 124
Fax +39 464 . 489 952

biaxitalia@biaxitalia.com
www.biaxitalia.com



**Hartmetall-Werkzeuge
Carbide Tools**

**Schmid & Wezel GmbH
Werk Hilsbach**

Breite Straße 38 | 74889 Sinsheim-Hilsbach
Germany

Tel. +49 7260 . 91 33 0
Fax +49 7260 . 91 33 25

flexwellen@biax.de
www.biax-flexwellen.de



**Biegsame Wellen
Flexible Shafts**



WWW.EFA-GERMANY.COM

SCHMID & WEZEL GMBH | Maybachstraße 2 | D-75433 Maulbronn
Tel. +49 (0) 7043 . 102 0 | Fax +49 (0) 7043 . 102 78 | efa-verkauf@efa-germany.de