

**REX**  
TECHNOLOGIE

VACUUM FILLER &  
PORTIONING SYSTEMS



UNIVERSAL  
FORMING MACHINE

# SHAPING IN PERFECTION

## UFM 300 – Universal shaping machines by REX-Technologie

The various models of the UFM 300 series are the ideal forming machines for all fresh meat and convenience food products. The various options for the UFM 300 make the machine the simplest way to shape all types of hamburgers, meatballs and dumpling products, and enable it to be operated as an attachment with all REX filling machines.

## DUMPLING SHAPING



## BURGER SHAPING



## CEVAPCICI SHAPING



300  
UFM



**UFM 300-1 – a single-row dumpling shaper for perfect forming**

The uncomplicated and automated way to shape dumplings. The form cutter mounted directly to the conveyor belt guarantees exact portioning and the form roller beneath creates the ideal shape. The rounded dumplings are then placed onto the conveyor belt. The form rollers are available in various diameters for a range of dumpling sizes. Beautifully round dumplings can be created from meat, potato, bread and various other food products.

Optional UV sterilisation for the FB 300 conveyor belt guarantees the highest possible level of bacterial eradication thus enhancing hygiene standards, giving machine suitability in high risk environments.

An attachment for producing čevapčići is also available.

**Flexible**  
thanks to various form roller diameters

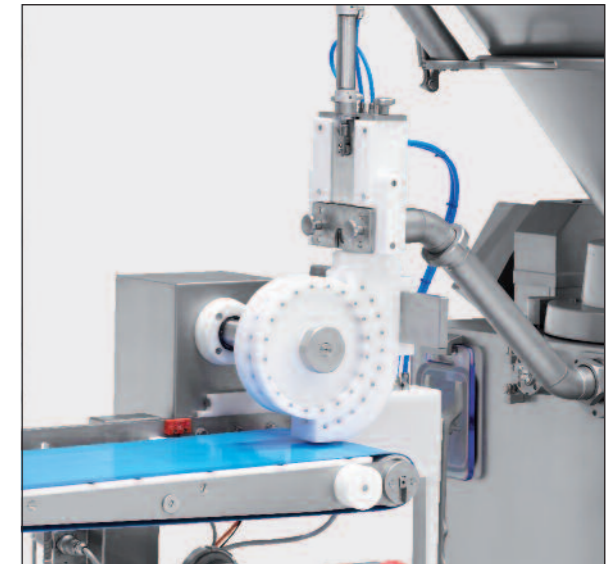

**Essential**  
a form roller for shaping



**Technical details**

Machine types	RVF 300, 400, 700, 900
Form rollers	from 20 to max. 60 mm
Portioning performance	up to max. 150 portions/min (depending on size)
Conveyor belt dimensions	length 1260 mm, width 320 mm
Supply voltage	230 volts + PE
Compressed air consumption	2 m³/h, 6 bar
Net weight	220 kg

**Dimensioned drawing UFM 300-1**

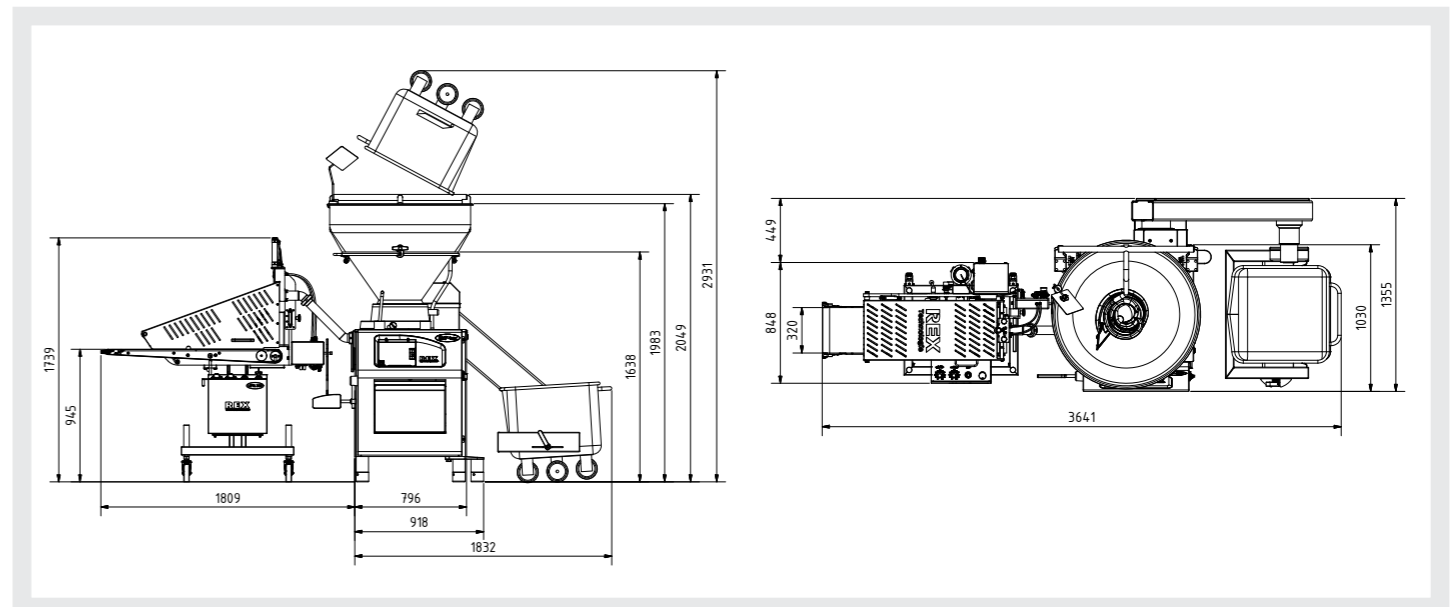

**UFM 300**



**UFM 300-2 / 300-3 / 300-4**  
the industrial dumpling forming solution

These provide an uncomplicated and automated way to shape dumplings. The filling flow divider separates the portions into several rows. The form cutter mounted directly to the conveyor belt guarantees exact portioning and the form rollers beneath create the ideal shape. The rounded dumplings are then placed onto the conveyor belt.

The form rollers are available in various diameters for all sizes of dumpling. Beautifully round dumplings can be created from meat, potato, bread and various other food products.

Optional UV sterilisation for the FB 300 conveyor belt guarantees the highest possible level of bacterial eradication thus enhancing hygiene standards, giving machine suitability in high risk environments.

**Exact portioning**  
thanks to the filling flow divider



**High performance**  
thanks to multi-row form rollers



**Technical details**

Machine types	RVF 300, 400, 700, 900
Form roller diameter	from 20 to max. 60 mm
Portioning performance	up to max. 600 portions/min (depending on the number of form rollers and size)
Conveyor belt dimensions	length 1260 mm, width 320 mm
Supply voltage	230 volts + PE
Compressed air consumption	2 m <sup>3</sup> /h, 6 bar
Net weight	max. 270 kg (depending on model)

**Dimensioned drawing UFM 300-2 / 300-3 / 300-4**

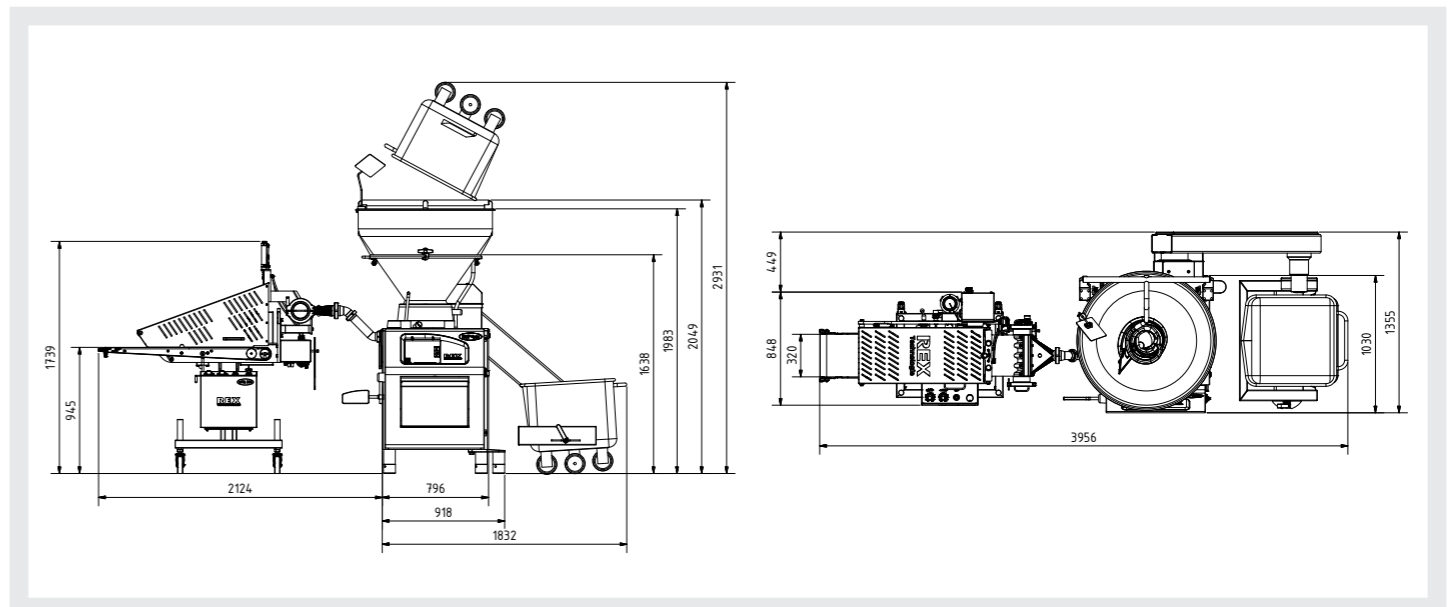

300  
UFM



**UFM 300-5 – the perfect “home-made” burger**

The new UFM 300-5 hamburger shaper is the optimal machine-based solution for producing hamburgers using the low-pressure process. The pneumatic form cutter directly linked to the REX filling machine cuts the portions, which are placed on the conveyor belt. The portions are then pressed into perfect “home-made” burgers via the form belt with optimal dimensional stability.

The water spraying unit prevents the product sticking to the blade or conveyor belts. An optional imprint roller can be mounted to the end of the conveyor belt to structure the burger surface.

Optional UV sterilisation for the FB 300 conveyor belt guarantees the highest possible level of bacterial eradication thus enhancing hygiene standards, giving machine suitability in high risk environments. An attachment for producing čevapčići is also available.

**Technical details**

Machine types	RVF 300, 400, 700, 900
Burger sizes	from 50 to max. 100 mm in 10 mm increments
Portioning performance	up to max. 150 portions/min (depending on size)
Conveyor belt dimensions	length 1260 mm, width 320 mm
Supply voltage	230 volts + PE
Compressed air consumption	2 m³/h, 6 bar
Water consumption	0,5 l/min, only drinking water
Net weight	210 kg

**Dimensioned drawing UFM 300-5**

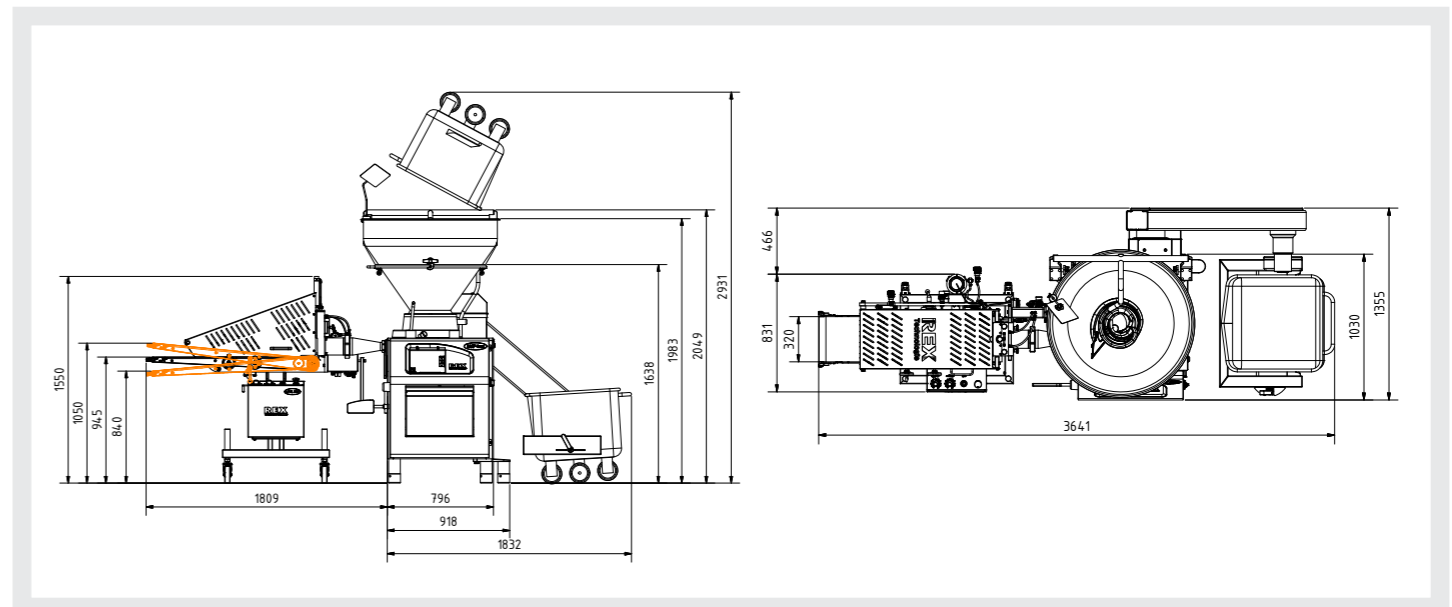

**Effective**  
pneumatic form cutter



**“Home-made”**  
using the form belt



**Optional**  
texturing roller



300-6  
UFM



**UFM 300-6 – the universal shaping wizard**

The UFM 300-6 is the universal solution for hamburger and dumpling production in combination with the REX filling machine. The modular structure enables a wide variety of products to be processed and shaped in a simple and economical way.

The new hamburger shaper is the optimal machine-based solution for producing hamburgers using the low-pressure process. The pneumatic form cutter cuts the portions. The portions are then pressed into perfect “home-made” burgers via the form belt with optimal dimensional stability. The water spraying unit prevents the product sticking to the blade or conveyor belts. An optional imprint roller can be mounted to the end of the conveyor belt to structure the burger surface.

By converting the form cutter for dumpling production, the form roller is able to shape single rows of beautifully round dumplings. The form rollers are available in various diameters for a range of dumpling sizes. Beautifully round dumplings can be created from meat, potato, bread and various other food products. Optional UV sterilisation for the FB 300 conveyor belt guarantees the highest possible level of bacterial eradication thus enhancing hygiene standards, giving machine suitability in high risk environments.

An attachment for producing čevapčići is also available.

**Technical details**

Machine types	RVF 300, 400, 700, 900
Burger sizes	from 50 to max. 100 mm in 10 mm increments
Portioning performance	up to max. 150 portions/min (depending on size)
Form roller diameter	from 20 to max. 60 mm
Conveyor belt dimensions	length 1260 mm, width 320 mm
Supply voltage	230 volts + PE
Compressed air consumption	2 m <sup>3</sup> /h, 6 bar
Water consumption	0,5 l/min, only drinking water
Net weight	260 kg

**Dimensioned drawing UFM 300-6**

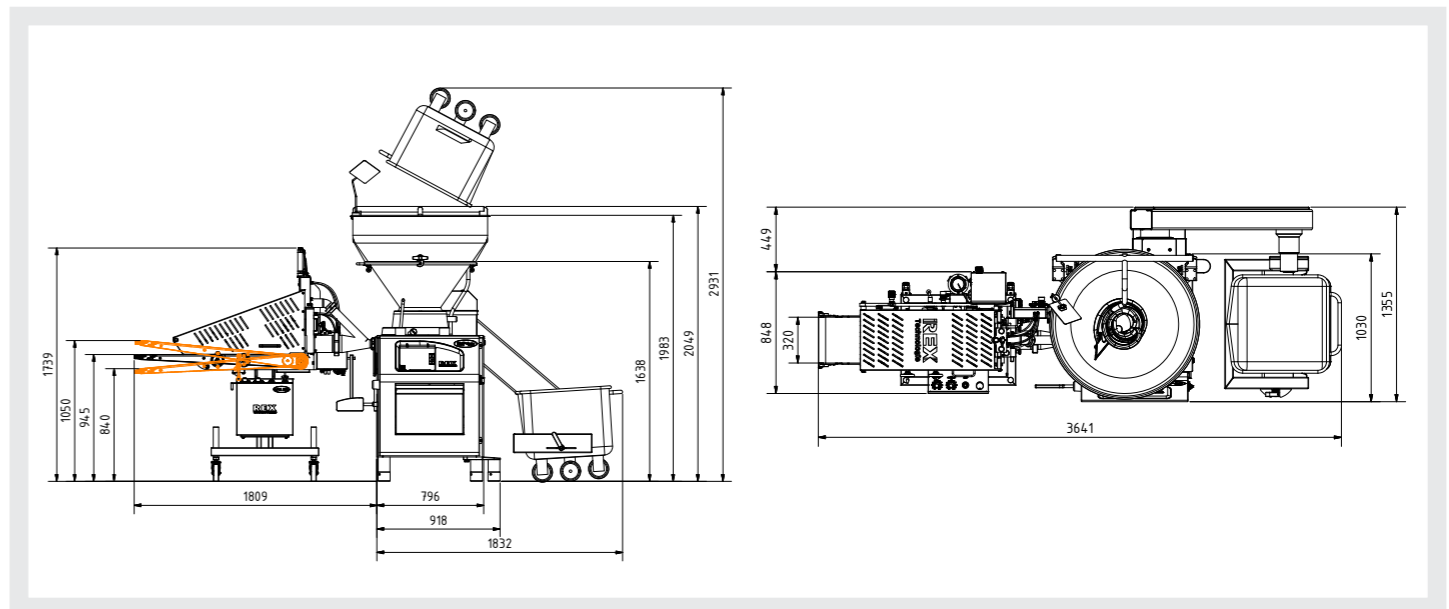

**Dumpling shaping**  
via the form roller

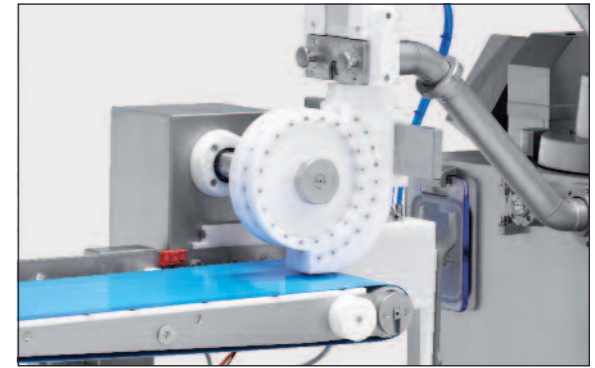

**Burger shaping**  
via the form cutter and form belt



**Optional**  
texturing roller





**300  
3  
M  
F  
U**

**UFM 300-1 / DUMPLING SHAPING**



**UFM 300-5 / BURGER SHAPING**



**UFM 300-7 / CEVAPCICI SHAPING**



**UFM 300 – the all-rounder for all moulded products**

The new UFM 300 is the flexible solution for forming hamburgers, meatballs and cevapcici. Directly connected to the Rex vacuum filling machine, it can be used to form all convenience products in its universal version. It can be changed over quickly and easily with just a few hand movements and ensures precise portioning and exact shaping by means of the various forming attachments depending on the application.

It can also be easily and quickly integrated into a fully automated line.

The optional UV-C light disinfection for the conveyor and forming belt helps to eliminate germs and thus increases the standard of hygiene.

**Dumpling shaping**  
by a forming roll

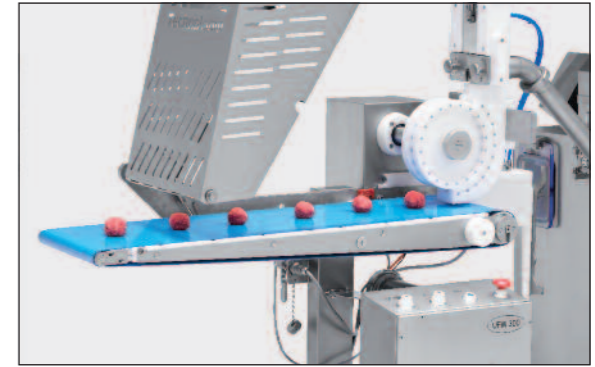

**Burger shaping**  
by form cutter & forming belt



**Cevapcici shaping**  
by flow divider & form cutter



**Technical details**

Machine types	RVF 300, 400, 700, 900
Burger sizes	from 50 to max. 100 mm in 10 mm steps
Portioning capacity burgers and dumplings	up to max. 150 port/min (depending on size)
Forming roll diameter dumplings	from 20 to max. 60 mm
Portioning capacity Chevapcici	up to max. 120 cuts/min (depending on size)
Mould inserts	2 to 8 times
Conveyor belt dimensions	1260 mm length, 320 mm width
Supply voltage	230 Volt + PE
Compressed air consumption	2 m³/h, 6 bar
Water consumption	0.5 l /min, drinking water only
Net weight	260 kg

**Dimensioned drawing UFM 300**

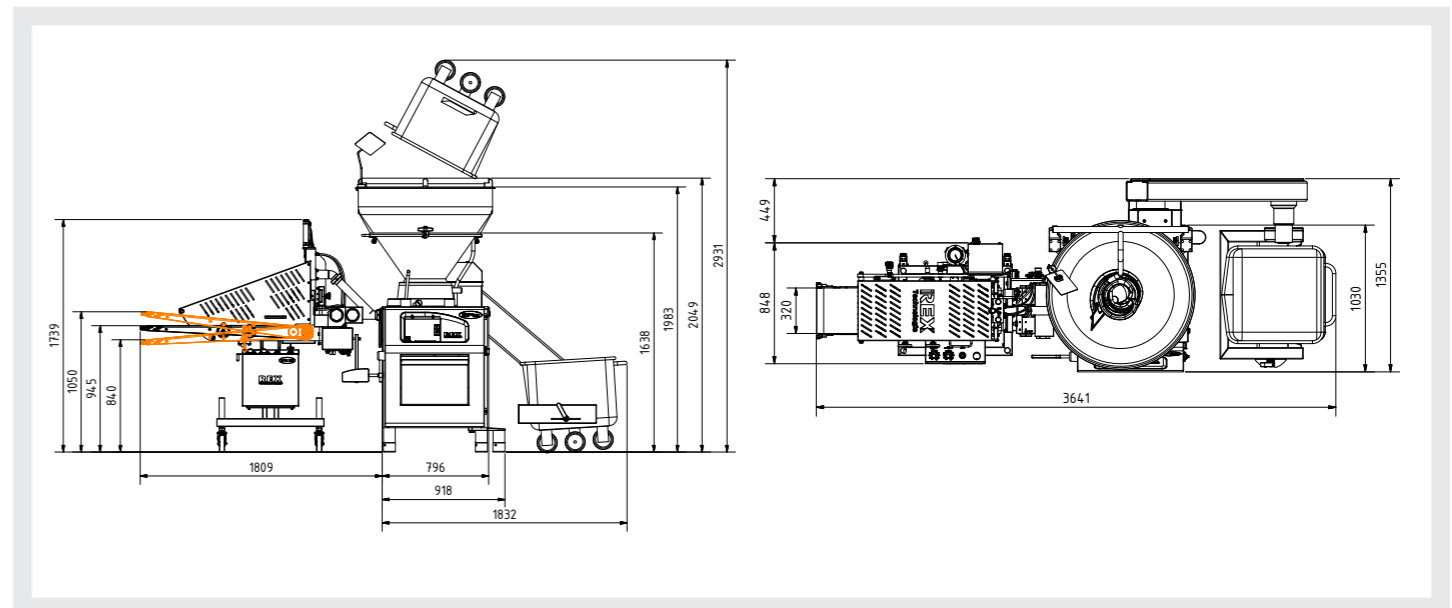





REX Technologie GmbH & Co. KG  
Irlachstrasse 31 • A-5303 Thalgau  
Phone +43(0)6235-6116-0 • Fax +43(0)6235-6529  
E-Mail: [sales@rex-technologie.com](mailto:sales@rex-technologie.com)  
[www.rex-technologie.com](http://www.rex-technologie.com)

